



- ▶ **Temperature Controllers**
- ▶ **Process Indicators**
- ▶ **Protection Relays**
- ▶ **Counters**
- ▶ **Meters**
- ▶ **Timers**
- ▶ **PLCs**

Our factory
at Mahape,
Navi Mumbai



Automated manufacturing

Fully automated,
latest technology
Electronic
manufacturing plant

Automated Testing

Automated testing &
calibration for
error free results



Mechanical Engineering

In house design,
tooling & plastics

Distribution

Wide distribution in India & around the World

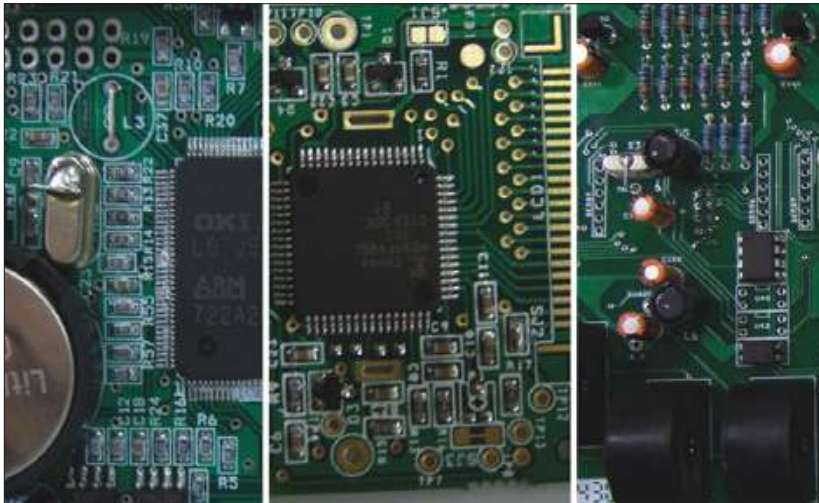

Technology

Time tested technology matured through continuous improvement & innovation

Certification

ISO 9001:2008

CE, UL marking for select products

A composite image showing a 'CERTIFICATE OF COMPLIANCE' from ICS (International Certification Services) for SELEC CONTROLS PVT. LTD. The certificate is for ISO 9001:2008 and covers the design, manufacture, and quality of electronic process control instruments. It also includes a screenshot of the 'ONLINE CERTIFICATION DIRECTORY' website, which lists the company's details and the scope of its certification.

Quality



Value

Creating Best Value

SELEC[®]
www.selec.com

NEW PRODUCTS



Multifunction Meter
Pg 08



Energy Meter
Pg 09



Digital Panel Meter
Pg 06



Digital Timers
Pg 21



Analog Timers
Pg 25



New TC Series
Pg 14

Contents

Programmable Logic Controllers	01
Accessories	04
Protection Relays	05
Digital Panel Meters	06
Electrical Panel Meters (Contd...)	07
Electrical Panel Meters	08
Energy Meters	09
Hotrunner Controllers	10
Advanced PID Temperature Controllers	11
Economical PID Temperature Controller	13
Economical PID Temperature Controller (New Series)	14
Process Indicator	16
Low Cost Digital Temperature Controllers	17
Digital Timers	19
Digital Timers (New Series)	21
Timers - 800 Series	22
Timers - 642 Series	24
Din Rail Timers - 600 Series (New Series)	25
Plug / Panel Mount Timers - 55 Series	26
Digital Counters	27
Rate Indicators / Switch	29
Totalisers & Time Measuring Instruments	30

Appendix

Accessories	31
Timing Diagrams	32
Dimensions	36

Programmable Logic Controllers

Single Box Solution



Built in:

- HMI
- I/Os
- Relays
- Analog (including temp. sensor inputs)
- 24V to drive inputs

- Upto 47 I/Os
- Upto 6 analog channels



MM3010

96 x 96

- Upto 8 Digital inputs
- Upto 5 Relays / Digital outputs
- One analog input



48 x 96

MM1010

MM1012

MM1013

	MM3010	MM1010	MM1012	MM1013
DISPLAY	LCD (backlight) 4 line x 16 character	7 segment LED, 3 digit + (4 + 4) digit		
No. of Keys	18 (10 numeric keys)	5		
No. of Configurable Keys	14	4		
DIGITAL SECTION				
• DIGITAL INPUT (Refer card selection table for available options)				
No. of Digital Inputs	Dependent on card selections (refer table 1.0 on Page 02)	8	6	8
Input Type	PNP	PNP		
Input Voltage Range	11 - 28V DC (abs. max.: 30V DC)	11 - 28V DC (abs. max.: 30V DC)		
Response Time (Inputs other than fast counter)	Programmable upto 1 - 255ms from front end (default 10ms)	Programmable upto 1 - 255ms from front end (default 10ms)		
Isolation	2 kV	2 kV		
Fast Counter Input				
Operating Modes / Frequency	Bidirectional, Unidirectional: 7.5 kHz Quadrature: 2.5 kHz	—		
Maximum Count	10 digits	—		
• DIGITAL OUTPUT - Relay (Refer card selection table for available options)				
No. of Relays	Dependent on card selections (refer table 1.0 on Page 02)	5	4	5
Relay (NO Type) Contact rating	4ch / 8ch: 5 A resistive @ 240V AC 11ch: 3 A resistive @ 240V AC	5 A resistive @ 240V AC 3A resistive @ 240V AC (for MM1010-24V only)		
Minimum Switching Time	10 msec	10 msec	20 msec	20 msec
Isolation	2kV	2kV		
• DIGITAL OUTPUT - Transistor (Refer card selection table for available options)				
No. of Transistor output	Dependent on card selections (refer table 1.0 on Page 02)	—		
Transistorised Output rating	For 14 Channels: PNP Type: 24V, 100mA	—		
Short Circuit Protection	Yes	—		
Max. Switching Frequency	1kHz	—		
ANALOG SECTION				
• ANALOG INPUT (Refer card selection table for available options)				
No of Inputs / Type	Dependent on card selections (refer table 1.0) TC / RTD / 0-20mA / 0-10V	1	2	—
Conversion Time	100msec	100msec		
Resolution	16 bit	16 bit		
• ANALOG OUTPUT (Refer card selection table for available options)				
No. of Analog Outputs	2	1		
Output Type	0-20mA / 0 - 10V (factory set)	0-20mA / 0 - 10V (factory set)		
Resolution	14 bit	14 bit		
Conversion Time	20 msec	20 msec		
Linearity Error	0.1%	0.1%		

MM3010

MM1010

MM1012

MM1013

● FUNCTIONAL SPECIFICATIONS		
Programming Method	Windows based software for ladder program & HMI configuration	Windows based software for ladder program & HMI configuration
Memory	Data memory: 16K Code memory: 351K, Upload memory: 96K	Data memory: 16K Code memory: 223K
No of Objects	Maximum 5000 (as per memory)	Maximum 5000 (as per memory)
Minimum Scan Time	200 μ sec	200 μ sec
FUNCTION BLOCKS		
Timer	Universal Timer: ON delay, OFF delay, Pulse, Up timer, Down timer (10 ms) , 1 ms timer	ON delay, OFF delay, Pulse timer, Up timer, Down timer, Universal Timer (10 ms), 1 ms timer
Counter	Up counter, Down counter, Up/down counter (Upto 10 digits)	Up counter, Down counter, Up / down counter (10 digit)
Other Blocks	PID Control (Autotuning), Analog input, Analog output, Time switch, Communication (Master)	PID Control (Autotuning), Analog input, Analog Output
Communication Ports	Master - RS485; Slave -RS232 / RS485 (selectable via Jumper)	1 RS485 port (slave) (Isolated)
Communication Protocol	MODBUS RTU	MODBUS RTU
Memory Retention	10 years	10 years
RTC	Yes	No
Supply Voltage	90 - 270V AC/DC, 24V DC, AC@50/60 Hz	90 - 270V AC/DC, 24V DC, AC@50/60 Hz
Temperature	Operating: 0 to 50°C Storage: -20 to 60°C	Operating: 0 to 50°C Storage: -20 to 60°C
Humidity (non-condensing)	95% RH	95% RH
Weight	564 gms	258 gms
Certifications	CE	CE (For MM1010 only)
Dimensions	Refer diagram D on page 36	Refer diagram H(V) on page 36
Ordering Code	Please see overleaf for ordering information	Please see overleaf for ordering information

There are 4 card slots internal to the unit. These cards are factory fitted but possible to select while ordering. Each card slot has some selectable card types that can be inserted. Detailed information regarding these cards is provided in adjacent table.

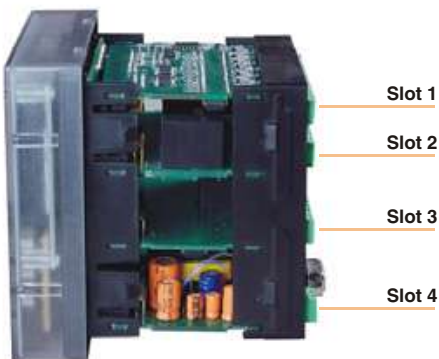
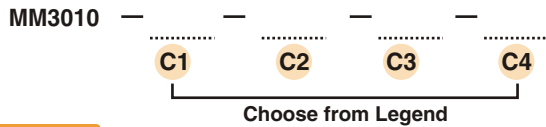

Table 1.0

I/O combinations available		Order Codes
Slot 1 Digital Input Cards	8 Digital Input	DI08
	13 Digital Input	DI13
	19 Digital Input + 1 Quad	DIQ19
Slot 2 Digital output Cards	8 Digital Output (Relay Type)	DR08
	11 Digital Output (Relay Type)	DR11
	14 Transistor Output, PNP, 100mA	DT14
Slot 3 Digital / Analog Mixed I/O Cards	Digital Mixed I/O: 8DI + 4DO	MDI08R04
	6 Channel Analog I/P: AI 06 (Thermocouple/RTD type)	AI06-T/R
	6 Channel Analog I/P: AI 06 (Voltage/current type)	AI06-V/I
	2 Channel Analog I/P: AI 02 (universal input)	AI02
	Analog Mixed I/O: 4AI + 2AO 4AI (Universal I/P) Set internal Jumpers (Default TC/RTD) 2AO (factory set) To be specified while ordering (0-10V/0-20mA)	MAI04O02
Slot 4 Power Supply	90 to 270V AC/DC	270 V
	24V DC	24V DC

Ordering Information (MM3010)



Legend

Digital Input Card		Digital Output Card		Digital/Analog Mixed Input Card		Power Supply	
C1	Configuration	C2	Configuration	C3	Configuration	C4	Configuration
DI08	8 Digital Inputs	DR08 Relay type	8 Digital Outputs	MDI08R04 Only relay type O/P available	8 Digital Inputs + 4 Relay Outputs	270 V	90 to 270V AC/DC
DI13	13 Digital Inputs	DR11 Relay type	11 Digital Outputs	AI06- T/R	6 Analog Inputs TC / RTD type	24V DC	24V DC
DIQ19	19 Digital Inputs + 1 Quad	DT14 Transistor type	14 Transistor Outputs, (100mA each)	AI06- V/I	6 Analog Inputs Voltage / Current type		
				AI02	2 Analog Inputs Universal type		
				*MAI04O02	4 Analog Inputs + 2 Analog Outputs		

NOTE

* In case of MAI04O02, type of Analog Input/Output to be specified separately.

INPUTS	OUTPUTS
TC	0-10V
RTD	0-20mA
Voltage	
Current	

Ordering Example

MM3010 - DI13 - DR11 - AI02 - 270V

MM3010 - Digital Inputs: 13 - Digital Outputs: 11 -
Analog Inputs : 2 - Supply Voltage : 90 to 270V AC/DC

Ordering Information (MM1010, MM1012 & MM1013)

Order Code	Supply Voltage
MM1010-T/R-24V DC	24V DC
MM1010- T/R-230V	90 to 270V AC/DC
MM1010-V-230V	90 to 270V AC/DC
MM1010-V-24V DC	24V DC
MM1010-I-230V	90 to 270V AC/DC
MM1010-I-24V DC	24V DC
MM1012-230V	90 to 270V AC/DC
MM1012-24V DC	24V DC
MM1012-1-230V	90 to 270V AC/DC
MM1012-1-24V DC	24V DC
MM1012-2-230V	90 to 270V AC/DC
MM1012-2-24V DC	24V DC
MM1013-230V	90 to 270V AC/DC
MM1013-24V DC	24V DC

NOTE

In case of MM1012 type of Analog Input/Output to be specified separately.

INPUTS	OUTPUTS
TC	0-10V (for MM1012-1)
RTD	0-20mA (for MM1012-2)
Voltage	
Current	

Accessories (to be ordered separately)

Communication cable
Part no. - ACH-001. (9 pin D-type cable)

Windows-based software for ladder programming
Part no. - ACD-003

Four Relay module
Part no. - AR - 04 - 5A - NONC (SPDT)
AR - 04 - 5A - NO (SPST)

Power Supply module
Part no. 1) AP-24V-500mA-NS131

RS485 to RS232 converter
Part no. - AC - RS485 - RS232 - 01 (non isolated)
AC - RS485 - RS232 - ISO (with isolation)



24V DC Power Supply



RS232-485 Converter



4 Relay Module

Supply Voltage	90-270V AC/DC@ 50-60Hz Max. input current 50 mA	90-270V AC/DC@ 50-60Hz Max. input current 50 mA	24V DC, 40 mA for 4 relays, each relay ON at 24V DC, 10 mA
Output	24V DC, maximum current 500 mA		4 relay outputs with NONC Contact rating: 5 A resistive/ 1 A inductive minimum switching time: 10 ms
Transmission Speed		9600 to 115200 BPS	
Transmission Mode		2-wire (half duplex)	
Isolation	2 kV	2 kV	2 kV
Temperature	Operating: 0 to 50°C Storage: -20 to 75°C	Operating: 0 to 50°C Storage: -20 to 75°C	Operating: 0 to 50°C Storage: -20 to 75°C
Humidity (non-condensing)	upto 95%	upto 95%	upto 95%
Weight	110 gms	80 gms	130 gms
Dimensions	Refer diagram P(I) on page 37	Refer diagram S on page 37	Refer diagram P(I) on page 37

Ordering Information

Product Name	Order Code	Product Name	Order Code
24VDC Power Supply	AP-24V-500 mA	RS232-RS485 Converter (without isolation)	AC-RS485-RS232-01
RS232-RS485 Converter (with isolation)	AC-RS485-RS232-ISO	4 Relay Module	AR-4-5A-NO/NC

FI400



Description	Frequency to current converter
Inputs (factory set)	a) Voltage pulse: 3 to 30 VDC or 3 wire DC proximity switch b) 2 wire Namur proximity switch
Max. Frequency	999, 99.9, 9.99, 0.999 Hz
Accuracy	± 0.5%
Sensor Supply	12V DC, 30 mA
Damping Factor	512, 256, 128, 64, 32, 16, 8 or 4 (selectable by push wheel)
Check Mode	To verify minimum & maximum output values
Output	a) 0-20mA / 4-20mA b) Pulse repeat output (open collector)
Supply Voltage	230 / 110V AC (user selectable), 50/60Hz
Temperature	Operating: 0 to 50°C Storage: -5 to 50°C
Humidity (non-condensing)	upto 95%
Weight	420 gms
Ordering Code	FI400 - Proximity: 3 wire DC proximity input FI400 - Ag 19: 2 wire namur proximity input

CBCTs for Earth Leakage Relay



Description	CBCT
CT Ratio	1200:1
Sizes (inner diameter)	35mm, 70mm, 120mm

Ordering Information

Inner Diameter (in mm)	Order Code
35	CBCT-35
70	CBCT-70
120	CBCT-120

Protection Relays



ELR 600



VPR 604



CPR 605



FPR 602

Description	Earth Leakage relay 3 Ø-4 wire & 1 Ø	Voltage Protection relay 3 Ø-4 wire	Current Protection relay 3 Ø-4 wire	Frequency Protection relay 1 Ø
Output Contact	1. Trip Relay: 1 SPDT: NO (5 A @250V AC) NC (3 A @250V AC) 2. Fail Safe Relay: 1 SPST: NO (10 A @ 250V AC)	Fail Safe Relay: 1 SPDT: relay with 7A @ 250 / 30	1. Normal Relay: 1 SPDT: NO (5A @250V AC) NC (3A @250V AC) 2. Fail Safe Relay: 1 SPST: NO (5A @ 250V AC)	1. Trip Relay: 1 SPDT: 5A @250V AC/24V DC 2. Fail Safe Relay: 1 SPST: 5A @ 250V AC/24V DC
Power Consumption	3VA	5VA	11VA	10.5VA
Nominal Values		240V AC	5A	50Hz
TRIP SETTING				
Leakage Current	via CBCT(see accessories on pg 4) 30,100,300,500 mA, 1,3,5,10,20,30 A			
Under Voltage		180V AC to 234V AC (Vn -% (25, 22.5, 20,17.5,15,12.5,10,7.5,5,2.5))		
Over Voltage		246V AC to 300V AC (Vn +% (2.5,5, 7.5,10,12.5,15,17.5,20,22.5,25))		
Over Current			30,40,50,60,70,80,90,100,110, 120 % of phase current	
Under Frequency				40,41,42,43,44,45,46,47,48,49 Hz
Over Frequency				51,52,53,54,55,56,57,58,59,60 Hz
LED Indication	Power ON, Trip, % of leakage / CBCT error	Normal operation,Under/Over voltage condition, Phase reverse condition	Power ON, Tripped condition	Normal operation(frequency within trip setting), Under & Over frequency
Hysteresis		Approx. 2% of trip levels (factory set)	5, 10, 15, 20, 25, 30% of trip current	-0.5 to 2Hz (dependent on under & over frequency trip settings)
Power ON Delay		Approx. 400 ms	Approx. 100 ms	Approx. 100 ms
Trip Time Delay	0 to 9 seconds (adjustable)	0.2 to 10 seconds (adjustable)	0.2 to 10 seconds (adjustable)	0 to 9 seconds (adjustable)
Accuracy	± 5% of F.S. (30,100,300,500 mA,1,3,5A) ± 12% of F.S. (10,20,30 A)	± 0.5% at constant condition	± 0.5% at constant condition	± 0.5% at constant condition
Reset	Below 85% of tripped level & in the presence of CBCT by: 1)Front reset 2)Remote reset 3)On power interruption	Auto reset on removal of fault condition	Auto reset on removal of fault condition	Auto reset on removal of fault condition
Rated Current			5 A	
CBCT Ratio	1200 : 1 (Please see page 4 for compatible CBCT selection)			
Phase Current			5 A, AC (50-60 Hz)	
Supply Voltage AC: 50 or 60 Hz	230V AC (± 15%)	240V AC (± 30%)	240V AC (± 25%)	240V AC (± 30%)
Temperature	Storage / Operating: 0 to 50°C	Storage / Operating: 0 to 50°C	Storage / Operating: 0 to 50°C	Storage / Operating: 0 to 50°C
Humidity (non-condensing)	95% RH	95% RH	95% RH	95% RH
Weight	190 gms	180 gms	130 gms	100 gms
Dimensions	Refer diagram P(I) on page 37	Refer diagram P(II) on page 37	Refer diagram P(II) on page 37	Refer diagram P(II) on page 37
Terminal Connections				
Ordering Code	ELR600	VPR604	CPR605	FPR602

Digital Panel Meters



Description	Digital Ammeter	Digital Voltmeter
Display	4 digit, 7 segment LED Display	3 digit, 7 segment LED display
Display Range	0 to 4960A (scaled as per CT)	0 to 516V
Input Range	50mA to 5A AC	50 V to 480V AC
Method	True RMS	True RMS
Accuracy	± 0.5% of F.S.	± 0.5% of F.S. over rated operating conditions
Measuring Element Drop	0.07V at 5A	0.23W at 480V AC input
Input Impedance	—	1M Ω (± 5%)
CT Primary	5, 10, 20, 30, 40, 50, 60, 75, 80, 100,150, 200, 250, 300, 400, 500, 600, 800,1000, 1200,1500,1600, 2000, 2500, 3000, 4000	
Continuous Max. Input Rating	6.2A AC	516V AC
Sampling Rate	3 samples / second	3 samples / second
Supply Voltage	240 VAC, ±20%, 50/60 Hz; 110VAC, ±20%, 50/60 Hz	240V AC, ± 20%, 50/60Hz; 110VAC, ±20%, 50/60 Hz
Power Consumption	3VA maximum	3VA maximum
Temperature	0 to 50°C	0 to 50°C
Humidity (non-condensing)	85% RH	85% RH
Weight	MA12: 170gm, MA202: 180gm, MA302: 180gm	MV15: 170gm, MV205: 180gm, MV305: 180gm



Description	Digital Frequency Meter	Digital Power Factor Meter
Display	4 digit, 7 segment LED Display	4 digit, 7 segment LED Display
Over Range / Under Range Indication	"Ovfr" (Over 99.99 Hz) "Ur" (Under 40.00 Hz)	
Resolution	0.01	0.001
Input Voltage Range	Self Powered	Self Powered
Input Measurement Range / Current Input Measurement	40.00 - 99.99 Hz	0.25 - 6A (AC)
Accuracy	± 0.05 Hz	± 0.5% ± 1 digit
Auxiliary Supply Voltage (Vn), Frequency Range	240 / 110VAC (± 20%), 45 - 65 Hz	240 / 110VAC (± 20%), 50-60 Hz
Supply Variation	0.75 to 1.25 x Vn	0.75 to 1.25 x Vn
Over Voltage	1.5 x Vn continuous, 2 x Vn (3s)	1.5 x Vn continuous, 2 x Vn (3s)
Electrical Connection	1Ø	1Ø 2 wire
Temperature	Operating: -20°C to 60°C ; Storage: -30°C to 80°C	Operating: -20°C to 60°C ; Storage: -30°C to 80°C
Ordering Code	MF16 ; MF316	MP14 ; MP314

DIMENSIONS: MA12,MV15,MF16,MP14 Refer diagram H(U) on page 36 ; MA302,MV305,MF316,MP314: Refer diagram Q(II) on page 37; MA202, MV205: Refer diagram W on page 37

Electrical Panel Meters



96 x 96

- 3 Ø (rms) Voltage
- 3 Ø (rms) Current
- 3 Ø power (Active, Reactive, Apparent)
- 3 Ø Power factor
- Frequency
- Programmable CT Primary



96 x 96

Applicable only for MFM383C

- 3 Ø (rms) Voltage
- 3 Ø (rms) Current
- 3 Ø Power (Active, Apparent)
- 3 Ø Power factor
- Frequency
- Energy
- Programmable CT Primary
- RS485 Communication (MFM383C)



96 x 96

Applicable only for VAF36

- Monitors average value of Voltage, Current & Frequency
- Programmable CT Primary



96 x 96

- Monitors average value of Voltage, Current & Frequency
- Programmable CT Primary

	MFM309	MFM383 / MFM383C	VAF32 & 36	VAF39
Description	Multifunction Meter	Multifunction Meter	V.A.F. Meter	V.A.F. Meter
Display	7 segment LED; Height: 0.5"	Liquid crystal display (with backlight)	VAF32: Liquid crystal display VAF36: Liquid crystal display (backlight)	7 segment LED; Height: 0.5"
Digits	3 rows of 3 digits	3 rows of 3 digits, Bar graph, 8 digits for energy	3 rows of 3 digits, Bar graph	3 rows of 3 digits
Input Type	3 Ø-4 wire & 1 Ø - 2 wire	3 Ø-4 wire & 1 Ø - 2 wire	3 Ø-4 wire & 1 Ø - 2 wire	3 Ø-4 wire & 1 Ø - 2 wire
Rated Input Current	5A max.	5A max.	5A max.	5A max.
Display Scrolling	Auto / Manual	Auto / Manual	Auto / Manual	Auto / Manual
Range		99999999 for energy		
Resolution*	0.01, 0.1, 1 (depending on CT Primary)	0.01, 0.1, 1, Auto shift from 0.1 to 1 for energy (depending on CT Primary)	0.01, 0.1, 1 (depending on CT Primary)	0.01, 0.1, 1 (depending on CT Primary)
Frequency	1) 50Hz 2) 60Hz	1) 50Hz 2) 60Hz	1) 50Hz 2) 60Hz	1) 50Hz 2) 60Hz
CT Primary	5 to 5000 programmable	5 to 5000 programmable	5 to 5000 programmable	5 to 5000 programmable
Burden (max)	0.2VA max per phase	0.2VA max per phase	0.2VA max per phase	0.2VA max per phase
Accuracy	As per table 1	As per table 1	As per table 2	As per table 2
Display Reset		Programmable (for energy)		
Memory		10 years (for energy)		
LED/Parameter Indication	LEDs for all measured parameters	1) LCD for all measured parameters 2) % of current in bar graph form	1) LCD for all measured parameters 2) % of current in bar graph form	LEDs for all measured parameters
Communication		RS485 (MODBUS) (MFM383C only)		
Supply Voltage	90 to 270V AC/DC	90 to 270V AC/DC		
Rated input Voltage_(L-N)	350V AC	350V AC	VAF32: 170 to 270V AC VAF36: 90 to 270V AC	90 to 270V AC
Temperature	Operating: 0 to 50°C Storage: -20 to 75°C	Operating: 0 to 50°C Storage: -20 to 75°C	Operating: 0 to 50°C Storage: -20 to 75°C	Operating: 0 to 50°C Storage: -20 to 75°C
Humidity (non-condensing)	85%	85%	85%	85%
Weight	238 gms	250 gms	VAF32 - 180 gms VAF36 - 220 gms	210 gms
Dimensions	Refer diagram Q(II) on page 37	Refer diagram Q(II) on page 37	Refer diagram Q(II) on page 37	Refer diagram Q(II) on page 37
Terminal Connections				
Ordering Code	MFM309	MFM383 MFM383-C (Communication)	VAF32 VAF36	VAF39

Measurement	Accuracy (%)	Measurement	Accuracy (%)
Voltage V_{L-N}	$\pm 0.5\%$ of F.S. +1 digit	Frequency	$\pm 0.1\%$ of F.S. $\pm 0.1\text{Hz}$
Voltage V_{L-L}	$\pm 1\%$ of F.S. +1 digit	Active Power	$\pm 1\%$ of F.S. +1 digit
Average Voltage V_{L-N}	$\pm 0.5\%$ of F.S. +1 digit	Apparent Power	$\pm 1\%$ of F.S. +1 digit
Average Voltage V_{L-L}	$\pm 1\%$ of F.S. +1 digit	Reactive Power	$\pm 1\%$ of F.S. ± 2 digits
Current	$\pm 1\%$ of F.S. +1 digit	Power Factor & Avg. Pf	± 0.01 PF +1 digit
Average current	$\pm 1\%$ of F.S. +1 digit	Energy	Class 1

Parameters	Accuracy	Measurement	Accuracy
Voltage V_{L-N}	$\pm 0.5\%$ of F.S.*	Average Current I_{avg}	$\pm 1\%$ of F.S.**
Voltage V_{L-L}	$\pm 0.5\%$ of F.S.*	Frequency	± 0.1 Hz
Average Voltage V_{L-N}	$\pm 0.5\%$ of F.S.*	* ± 2 digit ** ± 2 digit@50 Hz *** ± 2 digit@60 Hz	
Average Voltage V_{L-L}	$\pm 0.5\%$ of F.S.*	*Resolution is dependent on the type of parameter and the CT primary value. For further details, refer instruction manual.	
Phase current I	$\pm 1\%$ of F.S.** $\pm 2\%$ of F.S.***		

Multifunction Meter



- 3 Ø (True rms) Voltage
- 3 Ø (True rms) Current
- 3 Ø Power (Active, Reactive, Apparent)
- 3 Ø Power Factor
- Frequency
- Energy (Active, Reactive, Apparent)
- Programmable CT/PT primary/secondary
- Modbus RTU Communication (RS485) (Optional)
- Pulse Output

MFM384

Description	Multifunction Meter
Display	Liquid crystal display with backlight
Digits	4 rows of 4 digits, lowest 8 digits for energy display Bargraph representation for current
Input Type	3 Ø - 3/4 wire, 2 Ø - 3 wire, 1 Ø - 2 wire
Rated Input Current	10mA - 5A (6A max) (External CT must be connected for current more than 5A)
Display Scrolling	Automatic / Manual
Resolution*	For energy- 0.01k, 0.1k, 1k, 0.01M, 0.1M, 1M, 10M (depending upon CT ratio X PT ratio) For Power, Voltage & Current- Auto resolution For Power factor - Resolution is 0.001
Frequency	50 or 60Hz
CT Primary	1A or 5A to 10,000A (Programmable for any value) Note : 1A or 5A depends upon the CT secondary
CT Secondary	Programmable between 1A or 5A
PT Primary	100V to 500 kV
PT Secondary	100 to 500V AC (phase to phase)
Burden (max)	0.5VA max per phase @ 5A
Accuracy	As per table 1 Page No. 09

Display Reset	Programmable (for energy)
Memory Retention	10 years (for energy)
LCD/Parameter Indication	1) LCD for all measured parameters 2) % of current in bar graph form
Supply Voltage	85 to 270V AC
Rated input Voltage_(L-N)	19 to 519V AC (phase to phase), 50/60Hz 11 to 300V AC (phase to neutral), 50/60Hz
OUTPUT	Pulse Output: Voltage range - 24V DC Current capacity - 100 mA max Pulse Width: 100 ms ± 50 ms.
COMMUNICATION	RS485 MODBUS Communication (Optional)
Temperature	Operating: 0 to 50°C Storage: -20 to 75°C
Humidity (non-condensing)	85%
Weight	395 gms
Dimensions	Refer diagram Q(III) on page 37
Terminal Connections	
Order code	1) MFM384 2) MFM384-C (Communication)

Automatic Power Factor Controller



96 x 96
APFC336



96x96
APFC338/310/312/314/316

Description	Automatic Power Factor Controller	
Display	7 segment LED ; Height 0.5"	
Digits	3	4
Input Type	1 Ø - 2 wire	
Nominal Input Current	5 A	
PF Measurement Range	2 % to 120 % of rated current	
Error Indications	CT (Current) absent CT reverse Under Compensation Over Compensation	
Hysteresis	0.01 of Target PF	Programmable: 0.005 to 0.050
Capacitor Switch ON time	30 sec – Fixed	Programmable: 1.0 to 300.0 sec
Capacitor Switch OFF time	30 sec – Fixed	Programmable: 1.0 to 300.0 sec
Operating mode	Automatic/Manual	
Relay Switching Logic	First on First off	
Operating Frequency	45 – 65Hz	
Display Update Rate	2 sec	1 sec

Supply Voltage	90 to 270V AC/DC (AC: 50 or 60Hz)	
Power Consumption	3 VA max @ 230 VAC	
Temperature	Operating: 0 to 50°C ; Storage: -20 to 75°C	
Humidity (non-condensing)	85%	
Number of Stages*	6	APFC338 - 408 gms APFC310 - 428 gms APFC312 - 446 gms APFC314 - 471 gms APFC316 - 507 gms.
Weight	227 gms	Refer diagram G(Y) on page 38
Dimensions	Refer diagram Q(II) on page 37	

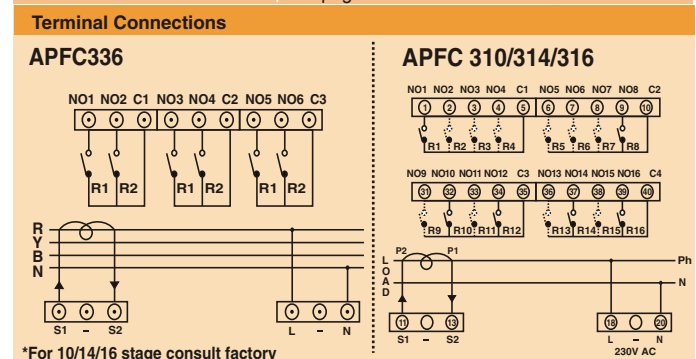

Energy Meter

SELEC[®]



- 3Ø Power (Active, Reactive)
- 3Ø Power Factor
- Energy (Active, Reactive, Apparent)
- Programmable C.T, P.T
- Modbus RTU Communication (RS485)
- Pulse Output

	EM306/EM306C	EM368/EM368C
Description	Energy Meter	Energy Meter
Display	7 segment LED ; Height 1.27mm	LCD display. Height 10.5mm
Digits	6	8
Input Type	3 Ø - 4 wire & 1 Ø - 2 wire	3 Ø - 3/4 wire, 2 Ø - 3 wire, 1 Ø - 2 wire
Rated Input Current	6 A max.	10mA - 5A (6A max) (External CT must be connected for current more than 5A)
Resolution	0.01, 0.1, 1 & 10 (depending on CT primary)	For energy- 0.01k, 0.1k, 1k, 0.01M, 0.1M, 1M, 10M (depending upon CT ratio X PT ratio) For Power - Auto resolution For Power factor - Resolution is 0.001
Frequency	50 Hz	50 or 60 Hz
CT Primary/ Secondary	5, 30, 40, 50, 60, 75, 80, 100, 150, 200, 250, 300, 400, 500, 600, 800, 1000, 1200, 1500, 1600, 2000, 2500, 3000, 4000, 5000	1A or 5A to 10,000A (Programmable for any value) Note : 1A or 5A depends upon the CT secondary
PT Primary/ Secondary	—	100V to 500kV / 100 to 500V AC
Burden	0.5 VA@5A per phase	0.5 VA@5A per phase
Accuracy	Class 1	Class 1 for Active/Apparent energy Class 2 for Reactive energy Class 0.5 for Power
LED Indications	Integration of energy, Resolution is 10, Reverse connected CT warning	Integration of energy, Resolution is 10, Reverse connected CT warning (All Indication on LCD)
Output	Pulse Output: Voltage range - 24V DC Current capacity - 100 mA max Pulse Width: 500 ms ± 50 ms.	Pulse Output: Voltage range - 24V DC Current capacity - 100 mA max Pulse Width: 100 ms ± 50 ms.
Supply Voltage	90 to 270V AC/DC	85 to 270V AC
Temperature	Operating: 0 to 50 °C Storage: -20 to 75 °C	Operating: 0 to 50 °C Storage: -20 to 75 °C
Humidity (non-condensing)	85 %	85 %
Communication*	RS485 communication (MODBUS protocol)	RS485 communication (MODBUS protocol)
Weight	225 gms	310 gms
Dimensions	Refer diagram Q(II) on page 37	Refer diagram Q(III) on page 37
Terminal Connections		
*For EM306-C/EM368-C consult factory		
Order code	1) EM306 2) EM306-C (Communication)	1) EM368 2) EM368-C (Communication)

TABLE 1

Accuracy : (MFM384)	Accuracy	Frequency	±0.1% , For Voltage >20V L-N, For Voltage >35V L-L
Measurement	Accuracy	Active Power	Class 1
Voltage V_{L-N}	±0.5% of Full scale	Apparent power	Class 1
Voltage V_{L-L}	±0.5% of Full scale	Reactive Power	Class 1
Average Voltage V_{L-N}	±0.5% of Full scale	Power factor and Avg Power Factor	±0.01
Average Voltage V_{L-L}	±0.5% of Full scale	Active energy	Class 1
Current	±0.5% of Full scale	Reactive energy	Class 1
Average current	±0.5% of Full scale	Apparent energy	Class 1

*Resolution is dependent on the type of parameter and the CT primary value. For further details, refer instruction manual.

Hotrunner Controllers

- Solid state high speed thyristor control
- Soft start
- Heater current indication
- Earth fault detection



TC75 (Single Zone, Two Zone, Four Zone, Six Zone, Eight Zone, Twelve Zone)

Description	Hotrunner controllers for accurate mould temperatures
Display	7 segment LED display
Digits	3 digit dual display Upper Display: PV and parameter name Lower Display: SV and parameter value (selectable)
LED Indications	8 LED indications on front panel
Inputs	Thermocouple: J and K type Range: 0 to 537°C (999°F)
Resolution	1° fixed
Control Accuracy	±1°C (1°F) dependent on total thermal system
Temperature Unit	°C or °F (selectable)
Response Time	250 ms
Control Action	Auto and Manual Control functions (Soft start system / Auto tune PID / ON-OFF Control modes)
Main Output	Internal solid state thyristor control Power capability : 15A @ 230V AC
Overload Protection	15A internal fuse
Manual Control	Adjustable from 0-100%, maintains output power within 1% of setpoint
Soft Start	Variable stepping voltage, 18 V to Line voltage
Special Functions	Heater current monitoring Heater current alarm Open triac or heater detection Ground fault detection Boost mode Standby mode
Supply Voltage	230 to 240V AC, -15% to 20% @ 50/60Hz
Power Supply Protection	15A internal fuse
Temperature	Operating: 0 to 50°C Storage: -20 to 75°C
Humidity (non-condensing)	85%
Weight	1 Zone: 2.8 kg 2 Zone: 4.6 kg 4 Zone: 9.5 kg 6 Zone: 11.9 kg 8 Zone: 15.6 kg 12 Zone: 20.5 kg
Dimensions	Refer table R on page 37

Ordering Information

TC75 —
A Choose from Legend

Accessories

Connectors

TCHTCN75 — A —
 Thermocouple & Heater Connector
B Choose from Legend

Cables

TCHTCL75 — A —
 Thermocouple & Heater Cable
C Choose from Legend

Legend

A		B		C	
Code	Zones	Code	Connector Type	Code	Length of cable
1	Single Zone	M	Male	4	4 meters
2	2 Zone	F	Female	5	5 meters
4	4 Zone			10	10 meters
6	6 Zone			15	15 meters
8	8 Zone			20	20 meters
12	12 Zone				

NOTE: For other configurations, consult factory

PID Temperature Controllers

Full Featured PID Series

SELEC[®]

PID500 / 110 / 330

- Heat cool
- Ramp soak
- Soft start
- Heater current monitoring
- Remote setpoint
- Motorised valve control
- RS485 communication

Profile Controller

- 10 programs, 16 steps each
- Alarm at each step
- Memory during power fail



Common specifications for PID500 / 110 / 330 & PR502

Description	Advanced PID controller, covers most applications
DISPLAY	Upper: 7 segment red LED Lower: 7 segment green LED
Digits	Upper: 4 digits (process value) Lower: 4 digits (selectable)
LED Indications	Relay ON, Alarm, Manual mode, Tune
INPUT SPECIFICATIONS	
Types	<i>Thermocouple:</i> J, K, T, R, S, C, E, B, N, L, U, W, Platinel II <i>RTD:</i> PT100 <i>Signal Inputs (DC):</i> -5 to 56 mV, 0 to 10 V, 0 to 20 mA
Sampling time	200 ms
Resolution	1 / 0.1° for TC/RTD 1/0.1/0.01/0.001 for analog input
Temperature Unit	°C / °F selectable
Indication Accuracy	
TC / RTD Input	For TC inputs: 0.25% of F.S. ±1° For R & S inputs: 0.5% of F.S. ±2° (20 min of warm up time for TC input) For RTD inputs: 0.1% of F.S. ±1° Cold junction accuracy ± 5°C
Signal Input	±0.5%, ± 1 digit
Control Output (Factory Set)	
Relay	5 A@230V AC or 30V DC
SSR	18V DC, 20mA
Current output	0/4 to 20mA DC (max. load :500E)
Voltage output	0 to 5/10V DC (min. load :10K)
Alarm Output	
Relay	Max. 2 (max.1 for PR502)
SSR	5A@230V AC or 30V DC
Retransmission Output	
Current Output	0/4 to 20mA DC (max. load :500E)
Voltage Output	0 to 5/10V DC (min. load :10K)
Update Rate	100 ms
FUNCTIONAL SPECIFICATIONS	
Control Method	PID or ON/OFF
Hysteresis	0.1 to 99.9°
Proportional Band	0.0 to 400.0°
Integral Time	0 to 3600 sec
Derivative Time	0 to 200 sec

Cycle Time	0.1 to 100 sec
Manual Reset Value	-99.9 to 99.9°
Heat Cool PID	
Control Method	PID
Cycle Time	0.1 to 100 sec
Proportional Gain	0.0 to 400.0°
Deadband	Programmable (SPLL to SPHL)
Alarms	
Modes	Deviation high/low, Absolute high/low, Band, Sensor break
Hysteresis	0.1 to 99.9°
Ramp Soak	
Ramp Rate	1 to 9999 °/hr
Soak Time	0 to 1440 min
Soft Start Time	
0 to 999 min	
OPTIONAL FEATURES FOR PID500	
Remote set point input	
Input Type	0 to 20mA DC / 0 to 10V DC
Input Resistance	100 ohm
Range	-5% to 105%
Scale Range	-1999 to 9999 with fixed 1° for TC/RTD and as per resolution selected for analog input
Heater current monitor input	
Input	100mA AC, 50 to 400Hz
Display Scale Range	0 to 999.9
Input Resistance	47 ohms
Accuracy	±0.5% F.S ±1 digit
Alarm mode	LA / HA / BAND
Over load	150 mA (continuous)
Motorised Value Input	
Closed Loop Feedback Input	Potentiometric Voltage Input Range: 0 to 10 VDC Current Input Range: 4 to 20 mADC
Motorised Control Mode	Bounded / Boundless
Manual Motor Control Modes	Rest / Run / Up / Down
Motor Position Indication (in %)	0.0 to 100.0%
Valve Travel Time	0.1 to 240.0 sec
Control Action (fixed)	Output1: Reverse action Output2: Forward Action

Serial Communication (Applicable for PR502/PID500/PID110/PID330)	
Interface standard	RS485
Communication address	1 to 99, maximum of 32 units per line
Transmission mode	Half duplex
Transmission protocol	MODBUS RTU
Transmission distance	500 m maximum
Transmission speed	9600, 4800, 2400, 1200, 600, 300 bits/sec
FUNCTIONAL SPECIFICATIONS FOR PR502	
No. of Profiles	10
Dimensions	
PID500: Diagram B, Page 36 ; PID110: Diagram H(W), Page 36 ; PID330: Diagram G(Y), Page 36 ; PR502: Diagram B, Page 36	

FUNCTIONAL SPECIFICATIONS FOR PR502 (continued)	
No. of Steps	16 each
Ramp / Soak Time Range	0.01 to 99.59 hrs : min
Target Temperature Range	SPLL to SPHL
Supply Voltage <small>AC: 50 or 60 Hz</small>	85 to 270V AC/DC Optional-24V AC/DC
Temperature	Operating: 0 to 50°C Storage: -20 to 75°C
Humidity (non-condensing)	95% RH
Weight	PID500: 180 gms ; PID110: 230 gms PID330: 330 gms ; PR502: 170 gms
Certifications	

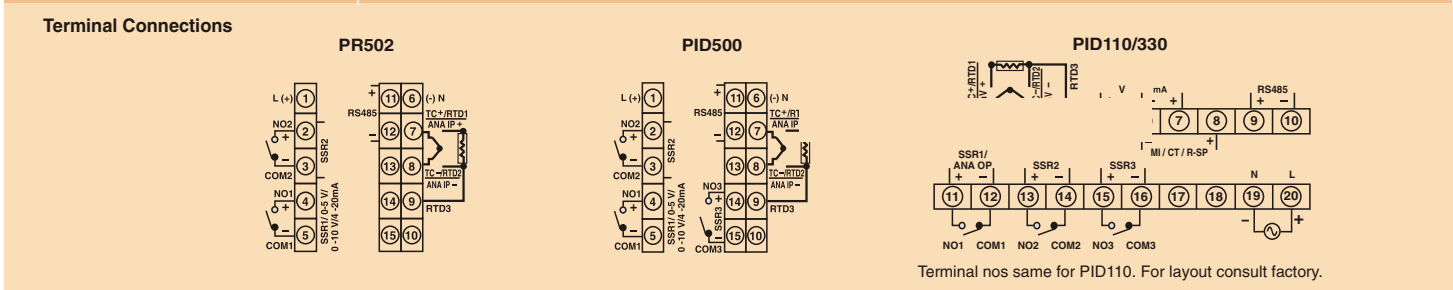

Ordering Information

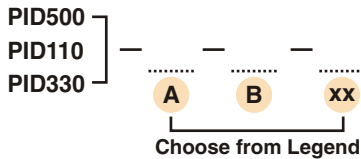

Legend

A		B		XX	
Output 1		Output 2		Output 3 / Special functions	
0	Relay	0	Relay	00	Only output 1 & 2
1	18V DC SSR Drive	1	12V DC SSR Drive	01	Output 3 (relay)
2	4-20mA (Current)			02	Output 3 (12V DC SSR drive)
3	0-10V (Voltage)			03	Communication RS485
4	0-5V (Voltage)			04	Output 3 (relay) + Communication RS485
5	0-20mA (Current)			05	Output 3 (12V DC SSR) + Communication RS485
				06	CT Input
				07	Output 3 (relay) + CT Input
				08	Output 3 (12V DC SSR) + CT Input
				09	CT Input+ Communication RS485
				Second Analog Input**	
				10	Valve positioner type
				11	Valve positioner type + Communication RS485
				12	Remote setpoint type
				13	Remote setpoint type+ Communication RS485

**Second Analog Input			
Valve positioner type		Remote setpoint type	
-P	Potentiometric f/b input	-C	4-20 mA input
-C	4-20 mA f/b input	-V	0-10 V input
-V	0-10 V f/b input		

****NOTE**

1) For 24V AC / DC model, add suffix '-24'.
2) For motorised, both the outputs can be Relay only.

For second analog I/P in PID110/330, consult factory.

Ordering Example

PID500 - 3 - 0 - 0 - 1

PID500 - Output 1 (Voltage) - Output 2 (Relay) - Output 3 (Relay)

Ordering Information(for PR502)

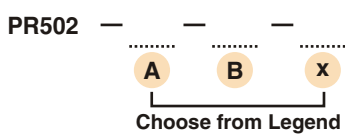

Legend

A		B		X	
Output 1		Output 2		Serial Communication	
0	Relay	0	Relay	0	No
1	18V DC SSR Drive	1	12V DC SSR Drive	1	Yes
2	4-20mA (Current)				
3	0-10V (Voltage)				

Ordering Example

PR502 - 3 - 0 - 1

PR502 - Output 1 (Voltage) - Output 2 (Relay) - Serial Communication (Yes)

PID Temperature Controllers

Economy Series



- High performance
- Simple to use
- Best value products in PID series

- 4 digit PV, 4 digit SV
- 2 set point
- Absolute / Deviation alarm

- 4+4 digit
- Single setpoint
- 10 A relay output 1C/O



PID528

48 x 48



TC518

48 x 48

Description	Economical PID	Economical PID
Display	7 segment LED, dual display	7 segment LED, dual display
Digits	4 + 4 digits	4 + 4 digits
LED Indications	Relay ON, Tune	Relay ON, Tune
INPUT SPECIFICATIONS		
Types	Thermocouple (J,K,T,R,S) / RTD (PT100)	Thermocouple (J,K,T,R,S) / RTD (PT100)
Sampling time	250 ms	250 ms
Resolution	1°/0.1°	1°/0.1°
Temperature Unit	Fixed °C	°C / °F selectable
Indication Accuracy**	For TC inputs: 0.25% of F.S. ±1° For R & S inputs: 0.5% of F.S. ±2° (20 min of warm up time for TC input) For RTD inputs: 0.1% of F.S. ±1°	For TC inputs: 0.25% of F.S. ±1° For R & S inputs: 0.5% of F.S. ±2° (20 min of warm up time for TC input) For RTD inputs: 0.1% of F.S. ±1°
Control Output		
Relay	5A@230V AC or 30V DC	10A@230V AC or 30V DC
SSR (optional)	18V DC, 20mA	18V DC, 20mA
Current (optional)	4-20mA DC (consult factory)*	
Auxiliary Output	Max. 1	
Relay	5 A@230V AC or 30V DC	
SSR (optional)	12V DC, 20mA	
Functional Specifications for Control		
Control Method	PID or ON/OFF	PID or ON/OFF
Hysteresis	0.1 to 99.9°	0.1 to 99.9°
Proportional Band	0.0 to 400.0°	0.0 to 400.0°
Integral Time	0 to 3600 sec	0 to 3600 sec
Derivative Time	0 to 200 sec	0 to 200 sec
Cycle Time	0.1 to 100.0 sec	0.1 to 100.0 sec
Manual Reset Value	-99.9 to 99.9°	-99.9 to 99.9°
Dwell (Soak) Timer		
Heat-Cool		
Control Method		
Proportional Band-Cool		
Cycle Time-Cool		
Dead Band		
Functional Specifications for Auxiliary O/P		
Modes	Deviation, Absolute	
Hysteresis	0.1 to 99.9°	
Supply Voltage	85 to 270V AC/DC, 24V AC/DC optional	85 to 270V AC/DC, 24V AC/DC optional
<small>AC: 50 or 60 Hz</small>		
Temperature	Operating: 0 to 50° Storage: -20 to 75°	Operating: 0 to 50° Storage: -20 to 75°
Humidity (non-condensing)	95% RH	95% RH
Weight	160 gms	160 gms
Certifications		
Dimensions	Diagram B on page 36	Diagram B on page 36

Terminal Connections

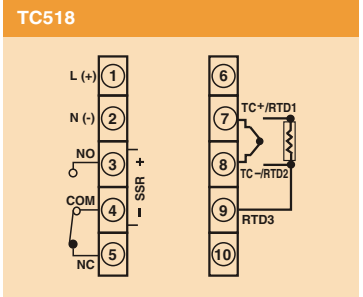
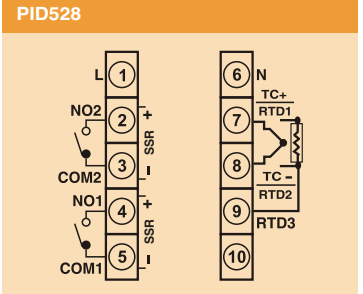

Ordering Information

PID528

Legend

A		
Code	Output 1	Output 2
1	Relay	Relay
2	18V DC SSR Drive	Relay
3	4-20mA	Relay
5	Relay	12V DC SSR Drive
6	18V DC SSR Drive	12V DC SSR Drive

Note: For 24V AC/DC model add suffix '-24'

Ordering example

PID528 - 2
PID528 - 18V DC SSR Drive - Relay Output1 Output2

TC518

Model	Output
TC518	Relay
TC518-SSR	18V DC SSR Drive

***Note:** For 24V AC/DC model, add suffix '-24'

Economic Temperature Controllers



- Heat-Cool Control
- Dwell timer ranging-OFF, 0 to 9999 min
- 1 alarm output - Absolute/deviation

- Programmable inputs
- Single setpoint
- Temperature unit °C / °F selectable

- Programmable inputs
- Single setpoint
- Temperature unit °C / °F selectable

- Programmable inputs
- Single setpoint
- Temperature unit °C / °F selectable



CE NEW TC544A/244AX/344AX

CE NEW TC533AX/233AX/333AX

CE NEW TC513AX/203AX/303AX

NEW DTC221A

Economical PID	Economical PID	Economical PID	Economical PID
7 segment LED, dual display	7 segment LED, dual display	7 segment LED, single display	7 segment LED, single display
4 + 4 digits	3 + 3 digits	3 digits	3 digits
Relay ON, Tune, Soak Time	Control output ON	Control output ON	Control output ON
Thermocouple (J,K,T,R,S) / RTD (PT100)	Thermocouple (J,K,T,R,S) / RTD (PT100)	Thermocouple (J,K,T,R,S) / RTD (PT100)	Thermocouple (J,K,T,R,S) / RTD (PT100)
250 ms	250 ms	250 ms	250 ms
0.1/1° for TC/RTD inputs (fixed 1° for R & S type TC input)	Fixed 1° resolution	Fixed 1° resolution	Fixed 1° resolution
°C / °F selectable	°C / °F selectable	°C / °F selectable	°C / °F selectable
For TC inputs: 0.25% of F.S. ±1° For R & S inputs: 0.5% of F.S. ±2° (20 min of warm up time for TC input) For RTD inputs: 0.1% of F.S. ±1°	For TC inputs: 0.25% of F.S. ±1° For R & S inputs: 0.5% of F.S. ±2° (20 min of warm up time for TC input) For RTD inputs: 0.1% of F.S. ±1°	For TC inputs: 0.25% of F.S. ±1° For R & S inputs: 0.5% of F.S. ±2° (20 min of warm up time for TC input) For RTD inputs: 0.1% of F.S. ±1°	For TC inputs: 0.25% of F.S. ±1° For R & S inputs: 0.5% of F.S. ±2° (20 min of warm up time for TC input) For RTD inputs: 0.1% of F.S. ±1°
5 A @250 VAC / 30 VDC, resistive	10 A @230 VAC or 30 VDC, resistive	10 A @230 VAC or 30 VDC, resistive	10 A @230 VAC or 30 VDC, resistive
12V DC, 50 mA	12V DC, 50 mA	12V DC, 50 mA	12V DC, 50 mA
Max. 1			
5 A @230V AC or 30V DC, resistive			
12V DC, 50 mA (Optional)			
PID or ON/OFF	PID or ON/OFF	PID or ON/OFF	PID or ON/OFF
0.1 to 99.9°	0.1 to 99.9°	0.1 to 99.9°	0.1 to 99.9°
1.0 to 400.0°	1 to 400°	1 to 400°	1 to 400°
0 to 9999 sec	0.0 to 99.9 min	0.0 to 99.9 min	0.0 to 99.9 min
0 to 9999 sec	0 to 200 sec	0 to 200 sec	0 to 200 sec
0.1 to 99.9 sec	0.1 to 99.9 sec	0.1 to 99.9 sec	0.1 to 99.9 sec
-19.9 to 19.9°	-19.9 to 19.9°	-19.9 to 19.9°	-19.9 to 19.9°
OFF, 1 to 9999 min			
PID (with auto-tuning)			
0.0 to 400.0°			
0.1 to 99.9 sec			
SPLL to SPHL (Programmable)			
Deviation, Absolute			
0.1 to 99.9°			
85 to 270V AC/DC, 24V AC/DC optional	85 to 270V AC/DC, 24V AC/DC optional	85 to 270V AC/DC, 24V AC/DC optional	85 to 270V AC/DC, 24V AC/DC optional
Operating: 0 to 50° Storage: -20 to 75°	Operating: 0 to 50° Storage: -20 to 75°	Operating: 0 to 50° Storage: -20 to 75°	Operating: 0 to 50° Storage: -20 to 75°
95% RH	95% RH	95% RH	95% RH
TC544A :142 gms TC244AX:190 gms TC344AX :252 gms	TC533A/AX: 129 gms, TC233AX: 180 gms TC333AX: 240 gms	TC513A/AX:129 gms, TC203AX:180 gms TC303AX: 240 gms	DTC221A: 180 gms

Diagram U on page 37

Diagram U on page 37

Diagram U on page 37

Diagram U on page 37

Terminal Connections

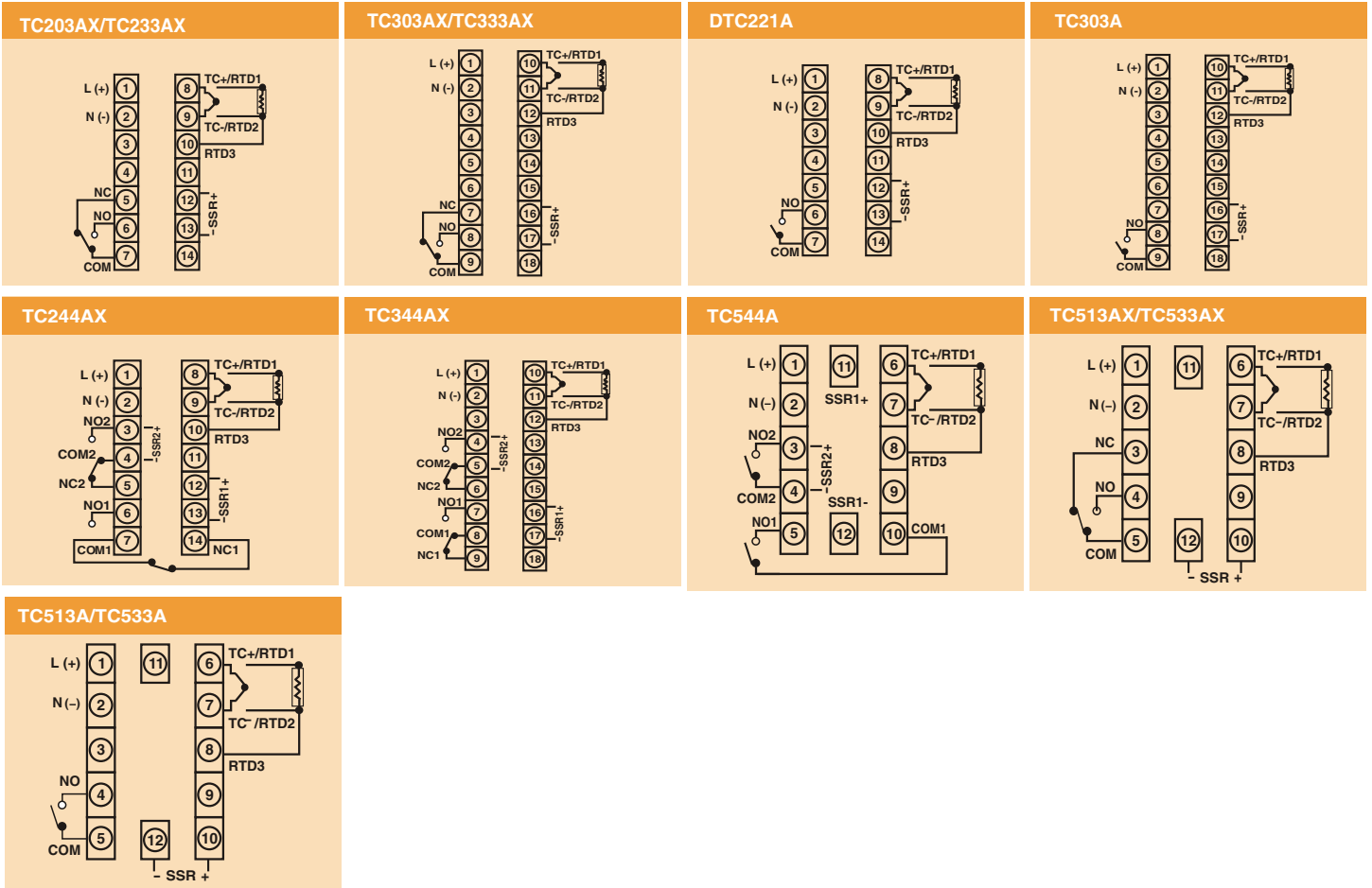

Ordering Information

TC513/TC203/TC303			TC533/TC233/TC333				TC544/TC244/TC344				
Part No.	Output 1		Part No.	Output 1		Part No.	Output 1		Output 2		
	Relay	SSR (12V DC)		Relay	SSR (12V DC)		Relay	SSR (12V DC)	Relay	SSR (12V DC)	
TC513A	▪		TC533A	▪		TC544A	▪	▪	▪		
TC513A-1		▪	TC533AX	▪	▪	TC544A-1	▪	▪		▪	
TC513AX	▪	▪	TC233AX	▪	▪	TC244AX	▪	▪	▪		
DTC221A	▪		TC333AX	▪	▪	TC244AX-1	▪	▪		▪	
DTC221A-1		▪				TC344AX	▪	▪	▪		
TC203AX	▪	▪				TC344AX-1	▪	▪		▪	
TC303A	▪										
TC303A-1		▪									
TC303AX	▪	▪									

*Note: For 24V AC/DC model, add suffix '-24'
 For TC513A/TC513A-1/TC533A/DTC221A/DTC221A-1/TC303A/TC303A-1 24V models are not available

Process Indicators

- 4 alarms
- Retransmission
- Communication



48 x 96

PIC1000N

- 2 alarms
- Retransmission



48 x 96

PIC152N

- Scalable Indicator



48 x 96

PIC101N

Description	4 Alarm outputs, Retransmission, Communication	2 Alarm outputs with retransmission.	Very low cost indicator (no output)
Display	4 digit, 7 segment LED : 0.5"	4 digit, 7 segment LED : 0.5"	4 digit, 7 segment LED : 0.5"
LED Indication	Alarm ON (4 Nos)	Alarm ON (2 Nos)	None
Error Indications	Over range/Under range/Open sensor/TC reverse	Over range/Under range/Open sensor/TC reverse	Over range/Under range/Open sensor/TC reverse
Inputs	Thermocouple: J, K, T, R, S, C, E, L, U, W, N, B, Platinell II RTD: PT100, PT1000 Signal Inputs (DC): -5 to 56 mV, 0 to 100 mV, 0 to 10V, 0/4 to 20 mA	Thermocouple: J, K, T, R, S RTD: PT100 Signal Inputs (DC): -5 to 56 mV, 0 to 10V, 0/4 to 20 mA	Thermocouple: J, K, T, R, S RTD: PT100 Signal Inputs (DC): 0 to 56 mV, 0 to 10 V, 0/4 to 20 mA
Resolution	Temperature input: 1/0.1°C / °F ; Signal input: 0.001, 0.01, 0.1 & 1.	For Temperature input: 1/0.1°C / °F ; For Signal input: 0.001, 0.01, 0.1 & 1.	For Temperature input: 1/0.1°C / °F ; For Signal input: 0.001, 0.01, 0.1 & 1.
Accuracy	For TC inputs: 0.25% of F.S. ±1° For R & S inputs: 0.5% of F.S. ±2° (20 min of warm up time for TC input) For RTD inputs: 0.1% of F.S. ±1° For Signal inputs: ±0.5% of F.S., ± 1 digit	For TC inputs: 0.25% of F.S. ±1° For R & S inputs: 0.5% of F.S. ±2° (20 min of warm up time for TC input) For RTD inputs: 0.1% of F.S. ±1° For Signal inputs: ±0.5% of F.S., ± 1 digit	For TC inputs: 0.25% of F.S. ±1° For R & S inputs: 0.5% of F.S. ±2° (20 min of warm up time for TC input) For RTD inputs: 0.1% of F.S. ±1° For Signal inputs: ±0.5% of F.S., ± 1 digit
Alarms	4 nos	2 nos	
Alarm Modes	High alarm, Low alarm, Band, Fail output and Fault diagnosis	High alarm, Low alarm, Band, Fail output and Fault diagnosis	
Hysteresis	0.1 to 99.9 °	0.1 to 99.9 °	
Annunciator	Programmable	Programmable	
Reset Action	Automatic or Latched	Automatic or Latched	
Relay Rating	5A @ 250V AC or 24V DC	5A @ 250V AC or 24V DC	
Retransmission Output (Optional)	0/4 to 20 mA DC, 0 to 5V DC, 0 to 10V DC	0/4 to 20 mA DC, 0 to 5V DC, 0 to 10V DC	
Sensor Supply	24V DC, 30 mA	24V DC, 30 mA	24V DC, 30 mA
Communication	RS485 (MODBUS)		
Supply Voltage	85 to 270V AC/ DC Optional - 24V DC	85 to 270V AC/ DC Optional - 24V DC	85 to 270V AC/ DC Optional - 24V DC
Temperature	Operating:0 to 50°C. Storage:-20 to 75°C.	Operating:0 to 50°C. Storage:-20 to 75°C.	Operating:0 to 50°C. Storage:-20 to 75°C.
Humidity (non-condensing)	95% RH.	95% RH.	95% RH.
Weight	260 gms.	240 gms.	200 gms.
Certifications			
Dimensions	Refer diagram H(V) on page 36	Refer diagram H(V) on page 36	Refer diagram H(V) on page 36
Terminal Connections	<p>Terminal block diagram for PIC1000N showing connections for mV/TC/RTD, ANALOG OUTPUT, sensor supply, and communication pins (N, L).</p>	<p>Terminal block diagram for PIC152N showing connections for mV/TC/RTD, ANALOG OUTPUT, sensor supply, and communication pins (N, L).</p>	<p>Terminal block diagram for PIC101N showing connections for mV/TC/RTD, ANALOG OUTPUT, sensor supply, and communication pins (N, L).</p>

Ordering Information

MODELS	RETRANSMISSION OUTPUT	COMMUNICATION	MODELS	RETRANSMISSION OUTPUT	MODELS
PIC1000-A	X	X	PIC152-A	X	PIC101N
PIC1000-D-1	0-20mA	X	PIC152-B-1	0-20mA	
PIC1000-D-2	4-20mA		PIC152-B-2	4-20mA	
PIC1000-D-3	0-5V		PIC152-B-3	0-5V	
PIC1000-D-4	0-10V		PIC152-B-4	0-10V	
PIC1000-E	-	✓			
PIC1000-E-1	0-20mA				
PIC1000-E-2	4-20mA				
PIC1000-E-3	0-5V				
PIC1000-E-4	0-10V				

Note: For 24V DC model add suffix '-24'

Digital / PID Temperature Controllers

Low Cost



DTC503 / 203 / 303

- J, K, PT100 (selectable)
- ON-OFF / Proportional control

PID513 / 213 / 313

- J, K, PT100 (selectable)
- PID Control



48 x 48



72 x 72



96 x 96

	DTC503-N / PID513-N	DTC203 / PID213	DTC303 / PID313
Description	Economical	Economical	Economical
Digits	3 digits	3 digits	3 digits
LED Indication	Output ON	Output ON	Output ON
Input Sensor (Range)	User selectable: J (-99 to 750) / K (-99 to 999) / PT100 (-99 to 850)	User selectable: J (-99 to 750) / K (-99 to 999) / PT100 (-99 to 850)	User selectable: J (-99 to 750) / K (-99 to 999) / PT100 (-99 to 850)
Resolution	Fixed 1°	Fixed 1°	Fixed 1°
Setpoints	1	1	1
Control Modes	DTC503: ON/OFF & Time proportional PID513: Autotune PID	DTC203: ON/OFF & Time proportional PID213: Autotune PID	DTC303: ON/OFF & Time proportional PID313: Autotune PID
Accuracy	±0.25% of F.S. ±1°C	±0.25% of F.S. ±1°C	±0.25% of F.S. ±1°C
Outputs	1 (1 C/O)	1 (1 C/O)	1 (DTC303/PID313: 1 NO, DTC303NX: 1C/O)
Relay Action	A) Heat mode B) Cool mode (for DTC503N only)	A) Heat mode B) Cool mode (for DTC203 only)	A) Heat mode B) Cool mode (for DTC303 only)
Relay Rating	10A @ 230V AC	10A @ 230V AC	10A @ 230V AC
Optional Output Configuration	12V DC, 20mA	12V DC, 20mA	12V DC, 20mA
Supply Voltage	85 to 270V AC/DC AC: 50 or 60 Hz	85 to 270V AC/DC 24V AC/DC (optional)	85 to 270V AC/DC 24V AC/DC (optional)
Temperature	Operating: 0 to 50°C Storage: -5 to 50°C	Operating: 0 to 50°C Storage: -5 to 50°C	Operating: 0 to 50°C Storage: -5 to 50°C
Humidity (non-condensing)	95% RH	95% RH	95% RH
Weight	140 gms	200 gms	210 gms
Certifications			
Dimensions	Diagram B on page 36	Refer diagram C on page 36	Refer diagram G(Z) on page 36
Terminal Connections	<p>Terminal 1: TC+ RTD1 Terminal 2: TC- RTD2 Terminal 3: short for TC Terminal 4: short for 2 wire RTD (PT 100) Terminal 5: RTD3 Terminal 6: L Terminal 7: N Terminal 8: NO Terminal 9: COM Terminal 10: NC Terminal 11: short for config Terminal 12: For SSR O/P</p> <p>NOTE: R - Red, W - White</p>	<p>Terminal 1: TC+ RTD1 Terminal 2: TC- RTD2 Terminal 3: short for TC Terminal 4: short for 2 wire RTD (PT 100) Terminal 5: RTD3 Terminal 6: W Terminal 7: L Terminal 8: N Terminal 9: For SSR O/P Terminal 10: NO1 Terminal 11: COM1 Terminal 12: NC1</p>	<p>Terminal 1: TC+ RTD1 Terminal 2: TC- RTD2 Terminal 3: short for TC Terminal 4: short for 2 wire RTD (PT 100) Terminal 5: RTD3 Terminal 6: W Terminal 7: L Terminal 8: N Terminal 9: SHORT FOR CONFIG Terminal 10: For SSR O/P Terminal 11: NO1 Terminal 12: COM1 Terminal 13: NO2 Terminal 14: COM2 Terminal 15: NO3 Terminal 16: COM3 Terminal 17: NO4 Terminal 18: COM4</p> <p>DTC303-NX with NC contact available</p>

Ordering Information

Model	Description
DTC503	48 x 48, ON/OFF & Time proportional
DTC203	72 x 72, ON/OFF & Time proportional
DTC303	96 x 96, ON/OFF & Time proportional, with 1 NO relay output
DTC303NX	96 x 96, ON/OFF & Time proportional, with 1 C/O relay output

Model	Description
PID513	48 x 48, Autotune PID
PID213	72 x 72, Autotune PID
PID313	96 x 96, Autotune PID

NOTE

For SSR output models: Add suffix 'SSR'
For 24V AC/DC models: Add suffix '24V'

Digital Temperature Controllers

Low Cost



- 2 setpoints
- J, K, PT100 (selectable)
- 0.1°C resolution for RTD
- ON-OFF / Proportional control



96 x 96

DTC324

Programmable, ON/OFF & Time proportional mode
4 digits
Output ON, Alarm ON
User selectable: J (-99 to 750) / K(-99 to 1350) / PT100 (-99 to 850.0)
1° for TC, 1/0.1° for RTD
2
Proportional / ON-OFF (Band/ Hysteresis: 0.1 to 99.9°) Cycle time: 1 to 99 sec.)
±0.25% of F.S. ±1°C
2
A) Heat mode B) Cool mode
Set 1: 10A @ 230V AC Set 2: 5A @ 230V AC
12 VDC, 20 mA
85 to 270 VAC/DC Optional: 24 VAC/DC
Operating: 0 to 50°C ; Storage ^a : -5 to 50°C.
95% RH
230 gms

Refer diagram G(Z) on page 38

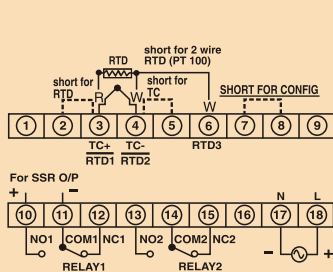

- 2 setpoints
- J, K, PT100 (selectable)
- 0.1°C resolution for RTD
- ON-OFF / Proportional control



72 x 72

DTC204

Programmable, ON/OFF & Time proportional mode
4 digits
Output ON, Alarm ON
User selectable: J (-99 to 750) / K(-99 to 1350) / PT100 (-99 to 850.0)
1° for TC, 1/0.1° for RTD
2
Proportional / ON-OFF (Band/ Hysteresis: 0.1 to 99.9°) Cycle time: 1 to 99 sec.)
±0.25% of F.S. ±1°C
2
A) Heat mode B) Cool mode
Set 1: 10A @ 230V AC Set 2: 5A @ 230V AC
12V DC, 20 mA
85 to 270V AC/DC Optional: 24V AC/DC
Operating: 0 to 50°C Storage: -5 to 50°C
95% RH
230 gms

Refer diagram C on page 36

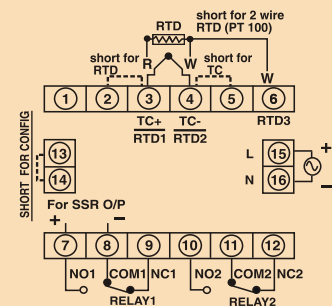

- J / K / PT100 versions
- ON-OFF / Proportional control



48 x 48

TC52

Analog temperature controller
Dial setting
Relay ON, Power ON
J (200 or 400) / K (200 or 400) / PT100 (200 or 400)
1
Time proportional & ON-OFF Control
Setting: ± 3% Repeat: ± 0.5% of F.S.
1
Heat mode
5A@230V AC
230V AC
Operating: 0 to 50°C Storage: -5 to 50°C
95% RH
130 gms

Refer diagram B on page 36

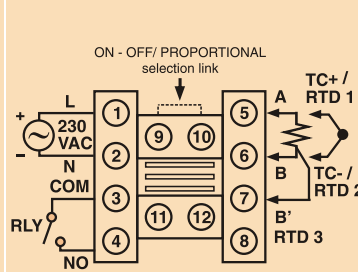

Cooling Controller

- 0.1°C resolution
- Defrost management
- High & low temperature alarm
- 20 A relay output



36 x 72

CH403

Controller for cooling applications
3 digits
Setpoint lock, Defrost, Relay ON, Alarm ON
NTC
1/0.1°
1
ON-OFF (Hysteresis: 0.1 to 9.9°)
±0.25% of F.S. ±1°C
2
Main, High Alarm, Low Alarm
Main output : 10A @ 230V AC or 20A; Alarm output : SSR drive 12V DC, 10mA or Relay 5A @ 230V AC
85 to 270V AC/DC Optional: 24V AC/DC
Operating: 0 to 50°C Storage: -5 to 50°C
95% RH
110 gms



Refer diagram F on page 36

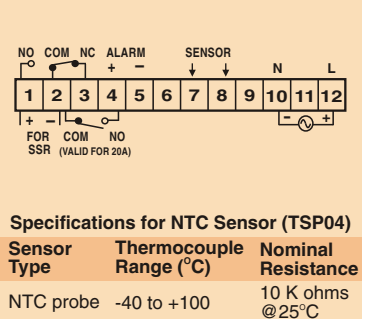

Ordering Information

Product Name	Order Code	Description
DTC204	DTC204-2	Relay Output
DTC324	DTC324	Relay Output
CH403	CH403-1	Main O/P : 10A Relay Alarm O/P : 12V DC, 10 mA
	CH403-2	Main O/P : 20A Relay Alarm O/P : None
	CH403-3	Main O/P : 10A Relay Alarm O/P : 5A Relay

Ordering Information (for TC52)

Model	Range	Sensor	Supply
TC52	200 - 0 to 200°C	J / K / PT100	230V AC
	400 - 0 to 400°C	J / K / PT100	230V AC

Ordering Example

TC52 - 400 - J - 230
TC52 (model) - 0 - 400°C - J Type Thermocouple - 230V AC supply

NOTE

For SSR output models: Add suffix 'SSR'
For 24V AC/DC models: Add suffix '24V'

- Low cost
- Single setpoint
- 2 C/O output



XT543

- Multifunction
- Multirange
- 2 setpoints



XT5042

- Preset
- 2 C/O output



XT56N

Description	Economical, multifunction programmable	Multifunction, dual display	High accuracy, push wheel setting
Display	7 segment LED; Height: 0.5"	Upper: 7 segment red LED; 0.5" Lower: 7 segment green LED ; 0.3"	7 segment LED; Height: 0.3"
Digits	3 digits	Upper: 4 digits Lower: 4 digits	3 digits
Time Setting	Front keypad	Front keypad	Pushwheel
No of Channels			
Operating Modes	ON delay / Interval delay / Cyclic ON first / Cyclic OFF first (refer page 35 for timing diagrams)	ON delay / Interval delay / Cyclic ON first / Cyclic OFF first / Forward-pause-reverse/ instantaneous + delayed / timer / batch (refer page 35 for timing diagrams)	ON delay / Interval
Setpoints	1	2	1
Range	9.99 / 99.9 / 999 sec, 9:59 min:sec 99.9 / 999 min, 9:59 hr:min, 99.9 / 999 hr	99.99 / 999.9 / 9999 sec, 99:59 min:sec, 999.9 / 9999 min, 99:59 hr:min, 999.9 / 9999 hr	9.99 / 99.9 / 999 sec, 99.9 / 999 min, 99.9 hr
Counting Direction	Down	Up / down	Down
Start Input	Gate / pulse start (programmable)	Gate / pulse start (programmable)	Pulse start
Accuracy	±0.5% of F.S. or 50 ms	±0.05% of F.S. or 50 ms	±0.05% of F.S. or 50 ms
Reset	Front, Remote, Power interruption	Front, Remote, Power interruption (programmable)	Front, Remote, Power interruption
Memory		10 years	
Configuration Lock	Via rear terminals	Password protected	
LED Indications	Relay status	Relay status, sec, min & hr	Relay status
Output	2 C/O (DPDT)	2, each 1 NO	2 C/O (DPDT)
Relay Rating	5A @ 230V AC	5A @ 230V AC	5A @ 230V AC
Supply voltage <small>AC: 50 or 60 Hz</small>	85 to 270V AC/DC	85 to 270V AC/DC, 24V DC (optional)	85 to 270V AC/DC
Temperature	Operating: 0 to 50°C Storage: -5 to 50°C	Operating: 0 to 50°C Storage: -5 to 50°C	Operating: 0 to 50°C Storage: -5 to 50°C
Humidity (non-condensing)	95% RH	95% RH	95% RH
Weight	130 gms	175 gms	140 gms
Certifications		CE	CE
Dimensions	Refer diagram B on page 36	Refer diagram B on page 36	Refer diagram B on page 36
Terminal Connections			
Ordering Code	XT543N	XT5042	XT56N

- Preset
- 2 C/O output

- Preset
- 2 C/O output

PT380 - 8 Channel Sequential Timer

- Flexibility of programming each channel separately
- Sequential / Parallel operation
- Cascade output for channel expansion



72 x 72



96 x 96



96 x 96

XT264

XT364

PT380

Description	Economical, pushwheel setting	Economical, pushwheel setting	Sequential timer
Display	7 segment LED; Height: 0.5"	7 segment LED; Height: 0.5"	7 segment LED; Height: 0.3"
Digits	3 digits	3 digits	2 + 4 digits
Time Setting	Pushwheel	Pushwheel	Front keypad
No of Channels			8 channels
Operating Modes	ON delay / Interval	ON delay / Interval	ON delay, Interval, Cyclic ON first, Cyclic OFF first (start up delay & no. of cycles programmable for cyclic mode) (refer page 35 for timing diagrams)
Setpoints	1	1	8
Range	9.99 / 99.9 / 999 sec, 99.9 / 999 min, 99.9 hr	9.99 / 99.9 / 999 sec, 99.9 / 999 min, 99.9 hr	99.99, 999.9, 99:59 min:sec, 99:59 hr:min, 999.9 hr
Counting Direction	Down	Down	Up
Start Input	Pulse start	Pulse start	Start, Hold
Accuracy	±0.5% of F.S. or 50 ms	±0.5% of F.S. or 50 ms	±0.5% of setting or 50 ms, whichever is greater
Reset	Front, Remote, Power interruption	Front, Remote, Power interruption	Front, remote, on power interruption
Memory			10 years
Configuration Lock			via rear terminals
LED Indications	Relay status	Relay status	Relay status, Cascade O/P , Time range, ON/OFF time, Timing in progress
Output	2 C/O (DPDT)	2 C/O (DPDT)	8 nos., NO with single common
Relay Rating	5A @ 230V AC	5A @ 230V AC	5A @ 230V AC
Supply voltage	85 to 270V AC/DC <small>AC: 50 or 60 Hz</small>	85 to 270V AC/DC	85 to 270V AC/DC
Temperature	Operating: 0 to 50°C Storage: -5 to 50°C	Operating: 0 to 50°C Storage: -5 to 50°C	Operating: 0 to 50°C Storage: -20 to 75°C
Humidity (non-condensing)	95% RH	95% RH	95% RH
Weight	200 gms	230 gms	350 gms
Certifications			
Dimensions	Refer diagram C on page 36	Refer diagram G(Z) on page 38	Refer diagram G(X) on page 36
Terminal Connections			
Ordering Code	XT264-3	XT364-3	PT380

Digital Timers

Multifunction Multi range timers



NEW 48 x 48

XT546



NEW 72 x 72

XT246



NEW 96 x 96

XT346

Description	Multifunction Dual Display	Multifunction Dual Display	Multifunction Dual Display
Display	7 segment LED, 3+3 digits Height : Upper display : 0.39" Lower display : 0.29"	7 segment LED, 3+3 digits Height : Upper display : 0.56" Lower display : 0.4"	7 segment LED, 3+3 digits Height : Upper display : 0.56" Lower display : 0.4"
Time Setting	Front keypad	Front keypad	Front keypad
Operating Modes	ON delay, Interval, Cyclic ON first, Cyclic OFF first (Refer page 35 for timing diagram)	ON delay, Interval, Cyclic ON first, Cyclic OFF first (Refer page 35 for timing diagram)	ON delay, Interval, Cyclic ON first, Cyclic OFF first (Refer page 35 for timing diagram)
Setpoints	1	1	1
Range	9.99 / 99.9 / 999 sec 9.59 min : sec, 99.9 / 999 min 9.59 hour : min, 99.9 / 999 hour	9.99 / 99.9 / 999 sec 9.59 min : sec, 99.9 / 999 min 9.59 hour : min, 99.9 / 999 hour	9.99 / 99.9 / 999 sec 9.59 min : sec, 99.9 / 999 min 9.59 hour : min, 99.9 / 999 hour
Counting Direction	Down	Down	Down
Start Input	Pulse, Gate (Programmable)	Pulse, Gate (Programmable)	Pulse, Gate (Programmable)
Accuracy	Setting : $\pm 0.05\%$ of set time or 50 ms (whichever is greater) Repeat : $\pm 0.05\%$	Setting : $\pm 0.05\%$ of set time or 50 ms (whichever is greater) Repeat : $\pm 0.05\%$	Setting : $\pm 0.05\%$ of set time or 50 ms (whichever is greater) Repeat : $\pm 0.05\%$
Reset	Front, Remote, Power interruption	Front, Remote, Power interruption	Front, Remote, Power interruption
Memory	10 years	10 years	10 years
Configuration Lock	Through front keypad	Through front keypad	Through front keypad
LED Indications	Relay status, Seconds, Minutes, Hours	Relay status, Seconds, Minutes, Hours	Relay status, Seconds, Minutes, Hours
Output	2:1 C/O (SPDT)	2:1 C/O (SPDT)	2:1 C/O (SPDT)
Relay Rating	5A @ 250V AC	5A @ 250V AC	5A @ 250V AC
Supply voltage AC : 50/60 HZ	85 to 270V AC, 24V AC/DC	85 to 270V AC, 24V AC/DC	85 to 270V AC, 24V AC/DC
Temperature	Operating: 0 to 50°C Storage: -20 to 75°C	Operating: 0 to 50°C Storage: -20 to 75°C	Operating: 0 to 50°C Storage: -20 to 75°C
Humidity (non-condensing)	95% RH	95% RH	95% RH
Weight	140 gms	190 gms	240 gms
Certifications			
Dimensions	Refer diagram U on page 37	Refer diagram U on page 37	Refer diagram U on page 37
Terminal Connections			
Ordering Code	XT546 / XT546-24V	XT246 / XT246-24V	XT346 / XT346-24V

22.5mm Din Rail Timers

800 Series

- Slim, space saving design
- Din rail / screw mounting
- Finger guards for safety
- Wide range of models



800XU



800XA



800M



800S



800XC

Description	2 functions, 12 ranges universal voltage	2 functions, 8 ranges universal voltage (economical)	2 functions, 12 ranges	Lowest cost, single range, single function	Cyclic with unequal ON time & OFF time
Modes ⁺¹	ON delay / Interval	ON delay / Interval	ON delay / Interval	ON: ON delay	Cyclic ON first or OFF first
Time Ranges	1 / 3 / 10 / 30 sec / min / hr	3 / 10 / 30 / 60 sec / min	1 / 3 / 10 / 30 sec / min / hr	30S: 30 sec, 60S: 60 sec (factory set)	1 / 10 sec / min / hr for both ON & OFF time
Accuracy	Setting: ± 5% of F.S. ; Repeat: ±0.5% or 50 ms	Setting: ± 5% of F.S. ; Repeat: ±0.5% or 50 ms	Setting: ± 5% of F.S. ; Repeat: ±0.5% or 50 ms	Setting: ± 5% of F.S. ; Repeat: ±0.5%	Setting: ± 5% of F.S., Repeat: ±0.5% or 50 ms
Reset	On interruption of power ; Reset time < 100 ms	On interruption of power ; Reset time < 100 ms	On interruption of power ; Reset time < 100 ms	On interruption of power ; Reset time < 100 ms	On interruption of power ; Reset time < 100 ms
LED Indications	Power ON, Relay ON	Power ON, Relay ON	Power ON, Relay ON	Power ON, Relay ON	Power ON, Relay ON
Output contacts	2 C/O (DPDT)	2 C/O (DPDT)	2 C/O (DPDT)	1: 1 C/O SPDT	2 C/O (DPDT)
Relay rating	5A@230V AC / 24V DC resistive	5A@230V AC / 24V DC resistive	5A@230V AC / 24V DC resistive	5A@230V AC / 24V DC resistive	5A@230V AC / 24V DC resistive
Supply voltage <small>AC: 50 or 60 Hz</small>	20 to 240V AC 12 to 240V DC	20 to 240V AC 12 to 240V DC	230: 230V AC	12: 12V DC 110: 110V AC 230: 230V AC 415: 415V AC (factory set)	20 to 240V AC 12 to 240V DC
Temperature	Operating: 0 to 50°C Storage: -20 to 75°C	Operating: 0 to 50°C Storage: -5 to 50°C	Operating: 0 to 50°C Storage: -5 to 50°C	Operating: 0 to 50°C Storage: -5 to 50°C	Operating: 0 to 50°C Storage: -5 to 50°C
Humidity (non-condensing)	95% RH	95% RH	95% RH	95% RH	95% RH
Weight	100 gms	100 gms	100 gms	70 gms	110 gms
Certifications					
Dimensions	Refer to diagram L on page 36				
Terminal Connections	<p>NOTE: Relay2 applicable for 2 C/O models only.</p>				
Ordering Code	800XU	800XA	800M-230 Supply Voltage 230V AC	800S-1-ON-30S-230 1 C/O, On delay, 30 sec, 230V AC 800S-1-ON-60S-230 1 C/O, On delay, 60 sec, 230V AC	800XC



IMPORTANT INFORMATION

+1 For detailed explanation of timing diagrams, refer to page no. 33 & 34.

Special function timers

800XMR

Forward - Pause - Reverse timer

Special timer for repetitive forward and reverse motion of motor with intermediate pause timing.

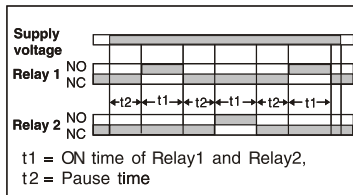

800POD

True power off delay timer

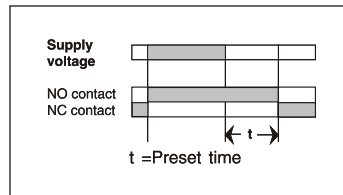

800SD-2 STAR DELTA TIMER

Special timer for star delta changeover.
For star-delta starting of 3 Ø induction motors

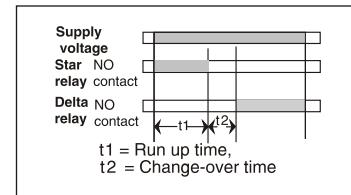

800XMR



800POD



800SQ-A



800SD-2

Description	Forward-pause-reverse	True power OFF delay timer	Low cost, 8 ranges, dual voltage	Star delta timer
Modes ⁺¹	Forward-pause-reverse	True power OFF delay	ON delay / Interval (factory set)	Star-Delta
Time Ranges	1 / 2 / 4 / 8 min (ON time) 10 / 20 / 40 / 80 sec (pause time)	60 : 60 sec, 180 : 180 sec (factory set)	3 / 10 / 30 / 60 sec / min (factory set)	Runup time range: 30/60 sec Change Over: 50/100 msec
Accuracy	Setting: ± 5% of F.S. ; Repeat: ±0.5% or 50 ms	Setting: ± 10% of F.S. ; Repeat: ±2% or 100 ms	Setting: ± 5% of F.S. ; Repeat: ±0.5%	Setting: ± 5% of F.S. ; Repeat: ±0.5% or 50 ms
Reset	On interruption of power ; Reset time < 100 ms	On interruption of power ; Reset time < 100 ms	On interruption of power ; Reset time < 100 ms	On interruption of power ; Reset time < 100 ms
LED Indications	Relay1 ON, Relay2 ON	Power ON	Power ON, Relay ON	Star Relay ON Delta Relay ON
Output contacts	1 C/O each for forward & reverse	2 C/O (DPDT)	1 C/O (SPDT)	1 C/O relay each for star & delta
Relay rating	5 A@230 VAC / 24V DC resistive	2.5 A@250 VAC / 28 VDC resistive	5 A@230 VAC / 24V DC resistive	5 A@230 VAC, resistive
Supply voltage <small>AC: 50 or 60 Hz</small>	20 to 240 VAC 12 to 240 VDC	110 to 240 VAC/DC	230 : 230 VAC & 24 VAC/DC 110 : 110 VAC & 24 VAC/DC	230 : 230 VAC, 415 : 415 VAC, 110 : 110 VAC (factory set)
Temperature	Operating: 0 to 50°C Storage: -5 to 50°C	Operating: 0 to 50°C Storage: -5 to 50°C	Operating: 0 to 50°C Storage: -5 to 50°C	Operating: 0 to 50°C Storage: -20 to 75°C
Humidity (non-condensing)	95% RH	95% RH	95% RH	95% RH
Weight	100 gms	110 gms	115 gms	90 gms
Certifications				
Dimensions	Refer to diagram L on page 36			
Terminal Connections				
Ordering Code	800XMR	800POD-60 Time Range: 60 seconds 800POD-180 Time Range: 180 seconds	800SQ-A-230 Supply Voltage 230V AC & 24V AC/DC 800SQ-A-110 Supply Voltage 110V AC & 24V AC/DC	800SD-2-230 Supply Voltage 230V AC 800SD-2-415 Supply Voltage 415V AC 800SD-2-110 Supply Voltage 110V AC



IMPORTANT INFORMATION

+1 For detailed explanation of timing diagrams, refer to page no. 33 & 34 .

17.5mm Din Rail Timers

642 Series

- Slim, space saving design
- Din rail / screw mounting
- Finger guards for safety



642UX



642SQ



642VTR-3

Description	13 functions, 8 ranges Universal voltage	Low cost, 4 ranges, 2 voltages	Under voltage time relay
Modes⁺¹	13 functions (ON delay, Interval delay, Pulse output, Repeat cycle equal(OFF first), Repeat cycle equal(ON first), delay on break, Delay on Make with Totalize, Delay on make / Delay on break, Interval after break, Interval with Totalize, Interval on Make / Interval on Break, Single shot, Retriggerable single shot)	ON delay / Interval	Under voltage time relay (ON delay) (refer pg 37 for timing diagrams)
Time Ranges	3 / 10 / 30 sec / min, 3 / 10 hr	15 / 60 sec, 7.5 / 60 min	5 to 15 min
Accuracy	Setting: $\pm 5\%$ of full scale ; Repeat: $\pm 0.5\%$ or 50 ms	Setting: $\pm 5\%$ of full scale ; Repeat: $\pm 0.5\%$ or 50 ms	Setting: $\pm 5\%$ of full scale ; Repeat: $\pm 0.5\%$ or 50 ms
Reset	On interruption of power ; Reset time < 100 ms	On interruption of power ; Reset time < 100 ms	On interruption of power ; Reset time < 200 ms
LED Indications	Power ON, Relay ON	Power ON, Relay ON	Power ON, Relay ON
Output contacts	1 C/O (SPDT)	1 C/O (SPDT)	1 C/O (SPDT)
Relay rating	5 A @ 230 VAC / 24V DC resistive	5 A @ 230 VAC / 24V DC resistive	5 A @ 230 VAC / 24V DC resistive
Supply voltage <small>AC: 50 or 60 Hz</small>	20 to 240 VAC 12 to 240 VDC	230 VAC & 24 VAC/DC 110 VAC & 24 VAC/DC	3 \emptyset / 4 w 380-415 VAC, P-P (50/60Hz)
Temperature	Operating: 0 to 50°C Storage: -20 to 75°C	Operating: 0 to 50°C Storage: -20 to 75°C	Operating: 0 to 50°C Storage: -20 to 75°C
Humidity (non-condensing)	95% RH	95% RH	95% RH
Weight	80 gms	50 gms	60 gms
Certifications	CE RU	CE RU	
Dimensions	Refer to diagram K on page 36		
Terminal Connections			
Ordering Code	642 UX	642 SQ-230 Supply Voltage 230V AC & 24V AC/DC 642 SQ-110 Supply Voltage 110V AC & 24V AC/DC	642 VTR-3 Supply Voltage 415V AC (phase to phase)

! IMPORTANT INFORMATION

+1 For detailed explanation of timing diagrams, refer to page no. 33 & 34.

17.5mm Din Rail Timers

600 Series

- Slim, space saving design
- Din rail mounting

SELEC[®]



Phase Sequence Relay



Description	Single function 10 time ranges	13 functions 10 time ranges
Modes	On delay	On delay (A), Interval (B) Pulse output (C) Cyclic equal ON first (D) Cyclic equal OFF first (Di) Delay on break (E) Delay with Totalise (Ai) Delay on make/Delay on break(F) Interval after break (H) Interval with totalise (Bi) Single shot (I) Retriggerable Single shot (J) Latching relay (K)
Time Ranges	1 / 3 / 10 / 30 Sec/min 1 / 3 hr	1 / 3 / 10 / 30 Sec/min 1 / 3 hr
Accuracy	Setting: ± 5% of full scale ; Repeat: ±0.5%	Setting: ± 5% of full scale ; Repeat: ±0.5%
Reset	On interruption of power; Reset time < 100 msec	On interruption of power; Reset time < 100 msec
LED Indications	Power ON, Relay ON	Power ON, Relay ON
Output contacts	1 C/O (SPDT)	1 C/O (SPDT)
Relay rating	NO/5A, NC/3A @ 250V AC	NO/5A, NC/3A @ 250V AC
Supply voltage AC : 50/60 HZ	240V AC & 24V AC/DC	20-240V AC/DC
Temperature	Operating: 0 to 50°C Storage: -20 to 75°C	Operating: 0 to 50°C Storage: -20 to 75°C
Humidity (non-condensing)	95% RH	95% RH
Weight	71gms	80 gms
Certifications	CE	CE
Dimensions	Refer to diagram V on page 37	Refer to diagram V on page 37
Terminal Connections		

Description	Phase sequence Relay
Modes	Phase Failure Trip: <70% of nominal voltage (<280V AC) Detect phase Sequence/Phase Reversed: Yes Hysteresis: 2% (factory set) Response Time: 100 msec max. Power On Delay: 100 msec
Time Ranges	
Accuracy	±3% of F.S. (F.S. = Full Scale)
Reset	Auto reset on removal of fault condition
LED Indications	Relay ON
Output contacts	1 C/O (SPDT)
Relay rating	NO/5A, NC/3A @ 250V AC
Supply voltage AC : 50/60 HZ	3Ø/3W 280 to 528 VAC P-P
Temperature	Operating: 0 to 50°C Storage: -20 to 75°C
Humidity (non-condensing)	95% RH
Weight	74 gms
Certifications	
Dimensions	Refer to diagram V on page 37
Terminal Connections	

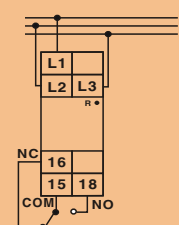
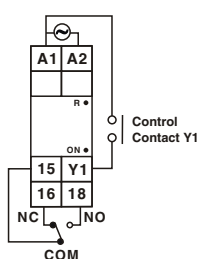
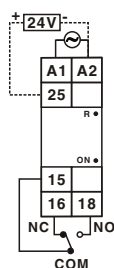

! IMPORTANT INFORMATION
+1 For detailed explanation of timing diagrams, refer to page no. 33 & 34.

Plug / Panel Mount Timers

55 Series

- Compact size
- Plug / panel mounting
- Wide range of models



48 x 48



48 x 48



48 x 48



48 x 48

	55XC	55XU	55M	55ES
Description	Cyclic with unequal ON & OFF time	2 functions, 12 ranges, universal voltage	2 functions, 12 ranges	Low cost, 8 range dual voltage
Modes⁺¹	Cyclic ON first or OFF first	ON delay / Interval	ON delay / Interval	ON delay / Interval
Base Type	P8 - 8 Pin plug T - Screw terminal	P8 - 8 Pin plug T - Screw terminal	P8 - 8 Pin plug T - Screw terminal	P8 - 8 Pin plug T - Screw terminal
Time Ranges	1 / 10 sec / min / hr for both ON time & OFF time	1 / 3 / 10 / 30 sec / min / hr	1 / 3 / 10 / 30 sec / min / hr	3 / 10 / 30 / 60 sec / min
Accuracy	Setting: ± 5% of F.S. ; Repeat: ±0.5% or 50 ms	Setting: ± 5% of F.S. ; Repeat: ±0.5% or 50 ms	Setting: ± 5% of F.S. ; Repeat: ±0.5% or 50 ms	Setting: ± 5% of F.S. ; Repeat: ±0.5% or 50 ms
Reset	On interruption of power ; Reset time < 100 ms	On interruption of power ; Reset time < 100 ms	On interruption of power ; Reset time < 100 ms	On interruption of power ; Reset time < 100 ms
LED Indications	Power ON, Relay ON	Power ON, Relay ON	Power ON, Relay ON	Power ON, Relay ON
Output contacts	2 C/O (DPDT)	2 C/O (DPDT)	2 C/O (DPDT)	1 C/O (SPDT)
Relay rating	5A@230V AC / 24V DC resistive	5A@230V AC / 24V DC resistive	5A@230V AC / 24V DC resistive	5A@230V AC / 24V DC resistive
Supply voltage <small>AC: 50 or 60 Hz</small>	20 to 240V AC 12 to 240V DC	20 to 240V AC 12 to 240V DC	230 : 230V AC	230 : 230V AC & 24V AC/DC 110 : 110V AC & 24V AC/DC
Temperature	Operating: 0 to 50°C Storage: -5 to 50°C	Operating: 0 to 50°C Storage: -5 to 50°C	Operating: 0 to 50°C Storage: -5 to 50°C	Operating: 0 to 50°C Storage: -5 to 50°C
Humidity (non-condensing)	95% RH	95% RH	95% RH	95% RH
Weight	80 gms	100 gms	90 gms	80 gms
Certification				
Dimensions	Refer to diagram A on page 36			
Terminal Connections				
Ordering Code	55XC - Base type Base type P8 - 8 pin plug T - Screw Terminal	55XU - Base type Base type P8 - 8 pin plug P11 - 11 pin plug T - Screw Terminal	55M - Base type - Supply voltage Base type P8 - 8 pin plug T - Screw Terminal Supply Voltage 230 : 230V AC	55ES - Base type - Supply voltage Base type P8 - 8 pin plug T - Screw Terminal Supply Voltage 230 : 230V AC & 24V AC/DC 110 : 110V AC & 24V AC/DC

! IMPORTANT INFORMATION
+1 For detailed explanation of timing diagrams, refer to page no. 33, 34

Digital Counters Totalisers

- 6 digits
- Inbuilt sensor supply



36 x 72

XC410

- 6 digits
- Inbuilt sensor supply



48 x 96

XC10D

- Self powered
- Long battery life
- Contact / AC input



24 x 48

LXC900

Description	6 digit totaliser	6 digit totaliser	LCD Counter
Display	Seven segment LED; Height: 0.3"	Seven segment LED; Height: 0.5"	Liquid crystal display, Height: 8 mm
Digits	6 digits	6 digits	8 digits
Sensor Type	NPN / PNP	NPN / PNP	
Input Type	Voltage pulse (3 to 30V DC) from Proximity switches, Solid state devices, Potential free contact encoder	Voltage pulse (3 to 30V DC) from Proximity switches, Encoders, Solid state devices, Potential free contact	V: Voltage pulse of 24 to 260V AC C: Potential free input
Input Speed	a) 0 to 20Hz b) 0 to 1kHz	a) 3Hz b) 30Hz c) 1kHz	a) 14Hz b) 100Hz
Operating Modes			
Setpoints			
Range	999999 counts	999999 counts	99999999 counts
Counting Direction	Up	Up	Up
Scale Factor			
Accuracy			
Reset	Front, Remote	Front, Remote	Front, Remote
Memory Retention	Yes	Yes	Yes
Sensor Supply	Inbuilt, 12V DC, 30mA	Inbuilt, 12V DC, 30mA	
LED Indications			
Output			
Relay Rating			
Supply voltage <small>AC: 50 or 60 Hz</small>	90 to 270V AC/DC, 24V AC/DC (optional)	90 to 270V AC/DC	Battery powered
Temperature	Operating: 0 to 50°C Storage: -5 to 50°C	Operating: 0 to 50°C Storage: -5 to 50°C	Operating: 0 to 50°C Storage: -20 to 75°C
Humidity (non-condensing)	95% RH	95% RH	95% RH
Weight	110 gms	200 gms	40 gms
Certifications	CE UL		CE UL
Dimensions	Refer to diagram F on page 36	Refer to diagram H(V) on page 36	LXC900: Refer diagram N on page 36
Terminal Connections			<p>Voltage Input</p> <p>Contact Input</p>
Ordering Code	XC410	XC10D	LXC 900- C : 24 x 48, Contact input LXC 900- V : 24 x 48, Voltage input

Digital Counters

Programmable / Preset

- 6 digit counter; 5 digit RPM indicator
- 2 setpoints
- Programmable input scaling
- Up, down, quadrature & bi-Directional



72 x 72

XC200NX

- 6 digit counter; 5 digit RPM indicator
- 2 setpoints
- Programmable input scaling
- Up, down, quadrature & bi-Directional



48 x 96

XC1200

- Multifunction timer cum counter
- 2 configurable setpoints
- Programmable input scaling
- Batch counting



48 x 48

XTC5400

- Preset counter
- Thumbwheel setting
- Auto reset
- Programmable input scaling
- Battery backup



72 x 72

XC22B

Multi function, quadrature input 2 setpoints	Multi function, quadrature input 2 setpoints	Multi-function, multi-range timer counter	4 digit preset counter
Seven segment LED; Height: 0.3"	Seven segment LED; Height: 0.5"	Upper: Seven segment red LED Lower: Seven segment green LED	Seven segment LED; Height: 0.5"
Total: 6 digits Rate: 5 digits	Total: 6 digits Rate: 5 digits	Upper: 4 digits Lower: 4 digits	4 digits
NPN	NPN	NPN / PNP	NPN / PNP
Voltage pulse (3 to 30V DC) from proximity switches, Encoders, Solid state devices, Potential free contact	Voltage pulse (3 to 30V DC) from proximity switches, Encoders, Solid state devices, Potential free contact	Voltage pulse (3 to 30V DC) from proximity switches, Encoders, Solid state devices, Potential free contact	Voltage pulse (3 to 30V DC) from proximity switches, Encoders, Solid state devices, Potential free contact
a) 0 to 30Hz b) 0 to 2.5kHz c) 0 to 5kHz (for up & down mode only)	a) 0 to 30Hz b) 0 to 2.5kHz c) 0 to 5kHz (for up & down mode only)	a) 3Hz b) 30Hz c) 5kHz	a) 0 to 30Hz b) 0 to 2kHz
ON delay / Interval delay / Auto reset / Time pulse repeat	ON delay / Interval delay / Auto reset / Time pulse repeat	Timer: ON delay, Interval, Cyclic ON first, Cyclic OFF first, Batch Counter: ON delay, Interval, Auto reset, Time pulse Repeat, Batch	ON delay / Interval delay / Auto reset
2	2	2	1
Count: Selectable least count 0.0001, 0.001, 0.01, 0.1 & 1 Rate: Auto ranging 4.00 to 99999 RPM or RPH mode	Count: Selectable least count 0.0001, 0.001, 0.01, 0.1 & 1 Rate: Auto ranging 4.00 to 99999 RPM or RPH mode	Timer: 99.99 / 999.9 / 9999 sec 99.59 min:sec, 999.9 / 9999 min 99.59 hr:min, 999.9 / 9999 hr Counter: -999 to 9999 counts	9999
Up, Down, Bidirectional, Quadrature	Up, Down, Bidirectional, Quadrature	Timer: Down Counter: Up / down	Up
0.00001 to 9.99999 x 10 ⁿ n= -5, -4, -3, -2, -1, 0, 1, 2	0.00001 to 9.99999 x 10 ⁿ n= -5, -4, -3, -2, -1, 0, 1, 2	0.001 to 9.999 x 10 ⁿ n= -3, -2, -1, 0, 1, 2	
Rate: 0.05% ± 2 counts	Rate: 0.05% ± 2 counts	Time: ± 0.05% of setting Counter: ± 0 counts	
Front (user selectable), Remote	Front (user selectable), Remote	Front, Remote, Power interruption	Front, Remote, Auto (optional)
Yes	Yes	Yes	Yes
Inbuilt, 12V DC, 30mA (short circuit protected)	Inbuilt, 12V DC, 30mA (short circuit protected)	12V DC, 30mA (short circuit protected)	Inbuilt, 12V DC, 30mA
Relay 1, Relay 2	Relay 1, Relay 2	Relay1, Relay2, sec, min, hr	Relay ON
2, 2 Relays each 1 C/O	2, 2 Relays each 1 C/O	2, 2 Relays each 1 NO	2 C/O (DPDT)
5A @ 230V AC/ 24V DC	5A @ 230V AC/ 24V DC	5A @ 230V AC	5A @ 230V AC
85 to 270V AC/DC	85 to 270V AC/DC	85 to 270V AC/DC Optional: 24V DC	230: 230V AC, 110: 110V AC
Operating: 0 to 50°C Storage: -5 to 50°C	Operating: 0 to 50°C Storage: -5 to 50°C	Operating: 0 to 50°C Storage: -20 to 75°C	Operating: 0 to 50°C Storage: -5 to 50°C
95% RH	95% RH	95% RH	95% RH
220 gms	230 gms	170 gms	320 gms



Refer diagram H(V) on page 36



Refer diagram B on page 36

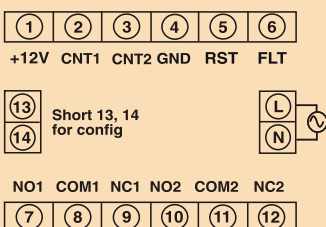

XC200NX

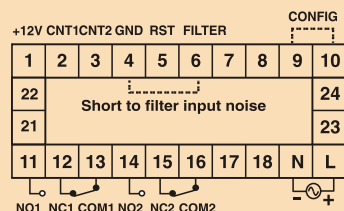

XC1200

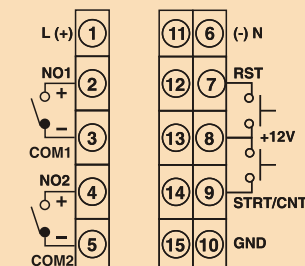

XTC5400, XTC5400-24 (24V DC)

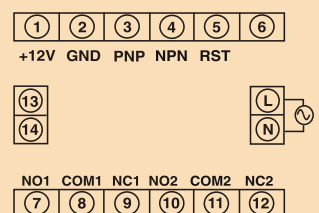

XC22B-4-230 : Without memory
XC22B-4-AR-M1-230 : With memory and Auto reset

Rate Indicators



- Measures upto 9999 RPM
- Inbuilt sensor supply



(72 x 72)

- Measures upto 9999 RPM
- Inbuilt sensor supply



(48 x 96)

- 6 digit count
- 4 digit rate
- Scalable input
- Inbuilt sensor supply



(48 x 96)

- Auto ranging RPM indicator
- Scalable input
- Measures upto 9999 RPM
- Input speed upto 3.5 kHz



(72 x 72)

- RPS, RPM, RPH indication
- Scalable input
- High & low alarm
- Programmable alarm delay



(72 x 72)

	RC2100	RC100	RC102C	RC2106	RC2108
Description	Rate indicator	Rate indicator	Rate indicator & totaliser	Rate indicator (scalable input)	Rate switch (with alarm)
Display	Seven segment LED; Height: 0.5"	Seven segment LED; Height: 0.5"	Seven segment LED; Height: 0.5"	Seven segment LED; Height: 0.5"	Seven segment LED; Height: 0.5"
Digits	4 digits	4 digits	Count: 6 digits Rate: 4 digits	4 digits	4 digits
Sensor Type	PNP / NPN*	PNP	PNP / NPN	PNP	PNP
Input Type	Voltage pulse (3 to 30V DC) from Proximity switches, Encoders, Solid state devices, Potential free contact	Voltage pulse (3 to 30V DC) from Proximity switches, Encoders, Solid state devices, Potential free contact	Voltage pulse (3 to 30V DC) from Proximity switches, Encoders, Solid state devices, Potential free contact	Voltage pulse (3 to 30V DC) from Proximity switches, Encoders, Solid state devices	Voltage pulse (3 to 30V DC) from Proximity switches, Encoders, Solid state devices, Potential free contact
Input Speed	4 to 9999 pulses/min.	4 to 9999 pulses/min.	a) 0 to 30Hz b) 0 to 2.5kHz	Upto 3.5kHz	Upto 3.5kHz
Setpoints					2 (Low alarm & High alarm)
Range	4.00 to 9999 rpm	4.00 to 9999 rpm	Count: 9999.99, 99999.9 999999 (user selectable) Rate: 4.00 to 9999 RPM	4.00 to 9999 RPM	4.00 to 9999 RPM
Modes					RPS, RPM, RPH (programmable)
Counting Direction	Unidirectional (Up)	Unidirectional (Up)	Unidirectional (Up)	Unidirectional (Up)	Unidirectional (Up)
Scale Factor			0.00001 to 9.99999 x 10 ⁿ n= -3, -2, -1, 0, 1, 2	0.001 to 9.999 x 10 ⁿ n= -3, -2, -1, 0, 1, 2	0.001 to 9.999 x 10 ⁿ n= -3, -2, -1, 0, 1, 2
Hysteresis					0 to 99 (LSD)
Power On Delay					0 to 999 sec
Alarm Delay					0 to 999 sec
Accuracy	Rate: 0.05%	Rate: 0.05%	Rate: 0.05% (±2 counts)	Rate: 0.05% (±1 count)	Rate: 0.05% (±1 count)
Reset			Front, Remote		
Memory			Current count value: 1 year Parameter setting: 10 years	10 years	10 years
Sensor Supply	Inbuilt, 12V DC, ±10%, 30mA	Inbuilt, 12V DC, ±10%, 30mA	Inbuilt, 12V DC, 30mA	Inbuilt, 12V DC, 30mA	Inbuilt, 12V DC, 30mA
LED Indications					Low alarm status, High alarm status
Output					1 C/O (SPDT) each for high & low alarm
Relay Rating					5A @ 230V AC/ 24V DC
Supply voltage <small>AC: 50 or 60 Hz</small>	85 to 270V AC/DC	85 to 270V AC/DC	85 to 270V AC/DC	85 to 270V AC/DC	85 to 270V AC/DC
Temperature	Operating: 0 to 50°C Storage: -5 to 50°C	Operating: 0 to 50°C Storage: -5 to 50°C	Operating: 0 to 50°C Storage: 0 to 50°C	Operating: 0 to 50°C Storage: -5 to 50°C	Operating: 0 to 50°C Storage: -5 to 50°C
Humidity (non-condensing)	95% RH	95% RH	95% RH	95% RH	95% RH
Weight	170 gms	180 gms	200 gms	170 gms	200 gms
Certifications			CE RoHS		
Dimensions	Refer diagram C on page 36	Refer diagram H(V) on page 36	Refer diagram H(V) on page 36	Refer diagram C on page 36	Refer diagram C on page 36
Terminal Connections	<p>* For NPN configuration please contact factory</p>				
Ordering Code	RC2100	RC100	RC102C	RC2106	RC2108

Time Measuring Instruments

- 6 digit time totaliser
- Selectable least count

- 4 digit time interval meter
- Ideal for measuring: MCB trip time, Relay changeover time
- Least count upto 0.0001 sec

- Self powered
- Long battery life
- Contact / AC input
- Front / Remote reset

- Low cost
- Self powered
- Long battery life
- Contact / AC input



	TT412; TT12	TI103	LT920	LT945
Description	Time Totaliser	Time Interval meter	Time Totaliser	Time Totaliser
Display	TT412 : 7 segment LED; Height: 0.3" TT12 : 7 segment LED; Height: 0.5"	7 segment LED; Height: 0.5"	Liquid crystal display	Liquid crystal display
Digits	6 digits	4 digits	8 digits	8 digits
Modes		Contact type, Stop watch, Pickup timer, Drop off timer, Pick up/drop off timer		
Range	99999.9 / 999999 / sec / min / hr	a) Autoranging: .0001 to 9999 sec b) Fixed ranges: .9999, 9.999, 99.99, 999.9, 9999 sec	a) 9999.59.59 hr:min:sec b) 999999.99 hr	999999.99 hrs
Direction	Up	Up	Up	Up
Input	Mains, Potential free contact, PNP sensor	Potential free contact, 3 to 30V DC from solid state devices	a) 24 to 260V AC b) Contact input	a) Contact input b) 24 to 260V AC (factory set)
Accuracy	0.05%	0.05%	0.05%	0.05%
Reset	Remote (Reset time: 20 ms)	Front, Remote, Auto (programmable)	Front, Remote	No reset
Memory	10 years		5 years	5 years
Configuration Lock	Via rear terminals			
Sensor Supply	12V DC (±10%) @ 30 mA (short circuit protected)	12V DC (±10%) @ 30 mA (short circuit protected)		
Supply voltage	85 to 270V AC/DC (AC: 50/60 Hz)	85 to 270V AC/DC (AC: 50/60 Hz)	Battery powered	Battery powered
Temperature	Operating: 0 to 50°C Storage: -5 to 50°C	Operating: 0 to 50°C Storage: -5 to 50°C	Operating: 0 to 50°C Storage: -20 to 75°C	Operating: 0 to 50°C Storage: -20 to 75°C
Humidity (non-condensing)	95% RH	95% RH	95% RH	95% RH
Weight	TT412: 90 gms TT12: 190 gms	190 gms	30 gms	50 gms
Certification			CE, RoHS	CE, RoHS
Dimensions	TT412: Refer diagram F on page 36 TT12: Refer diagram H(V) on page 36	Refer diagram H(V) on page 36	LT920: Refer diagram N on page 36	Refer diagram M on page 36
Terminal Connections	<p>TT412</p> <p>TT12</p>		<p>Voltage Input</p> <p>Contact Input</p>	<p>Voltage Input</p> <p>Contact Input</p>
Ordering Code	TT412 TT12	TI103	LT920-C : 24 X 48, Contact input LT920-V : 24 X 48, Voltage input	LT 945- C : 48 x 48, contact input LT 945- V : 48 x 48, Voltage input

Accessories

Adapter plates

To fit smaller products into 92 mm x 92 mm size, 69 mm x 69 mm or 48 mm x 48 mm size cutouts

Material: ABS



Model: AP9672

To fit 72 mm x 72 mm product into 92 mm x 92 mm cutout



Model: AP9648

To fit 48 mm x 48 mm product into 92 mm x 92 mm cutout



Model: AP7248

To fit 48 mm x 48 mm product into 69 mm x 69 mm cutout



Model: AP6050



Model: AP4848

SNUBBER CIRCUIT

R - C network to reduce electrical noise

Model: APRC01



TRANSPARENT FULL COVER

Material: Polycarbonate

Size: To fit 48 mm x 48 mm products

Model: ACF4801



8 PIN SOCKET

Mounting: a) DIN rail mounting b) Surface mounting

Model: AS08



48 x 48 COLLAR CLAMP

Model: ACL4802



Timing Diagrams for XTC5400

TIMER MODE

1. ON delay

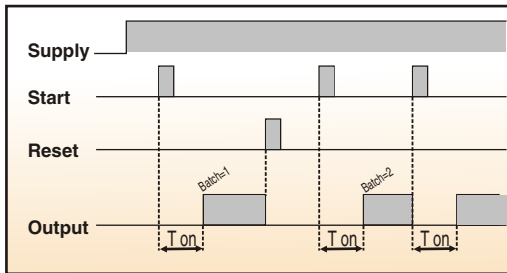

2. Interval

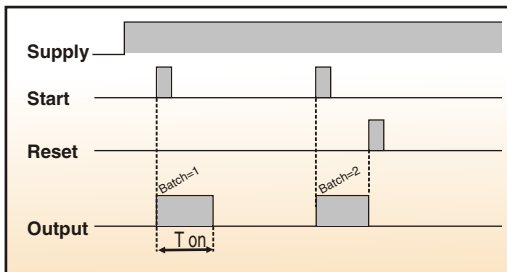

3. Cyclic ON - First

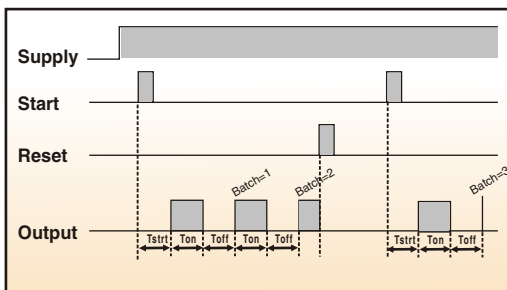

4. Cyclic OFF - First

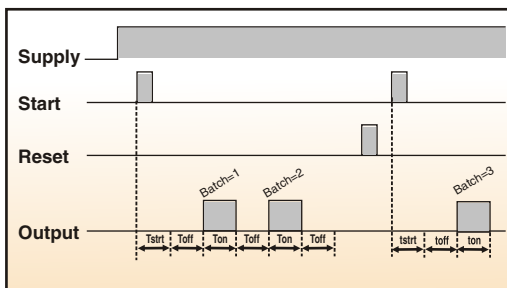

5. Batch mode

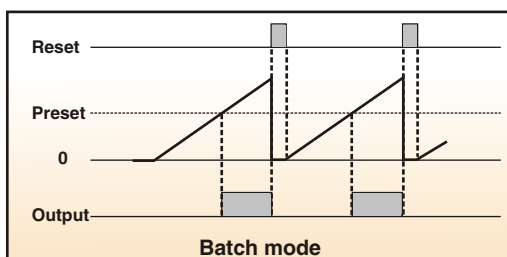

COUNTER MODE

1. ON Delay (OR mode)

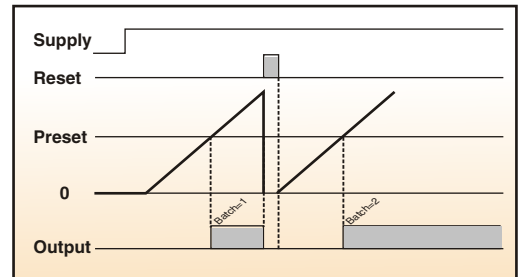

2. Interval (OR mode)

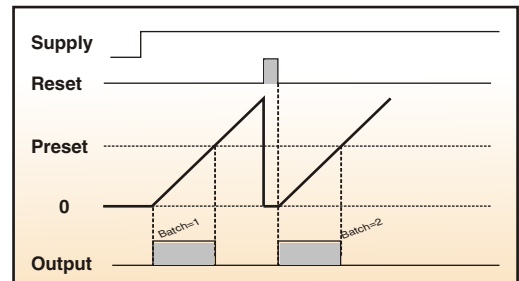

3. Auto Reset (NOR mode)

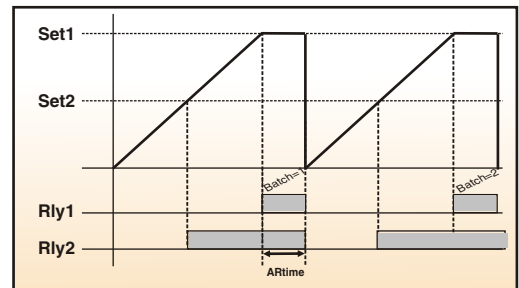

4. Time Pulse Reset (NOR mode)

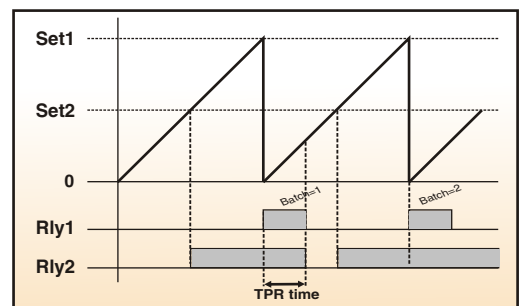

5. Batch mode

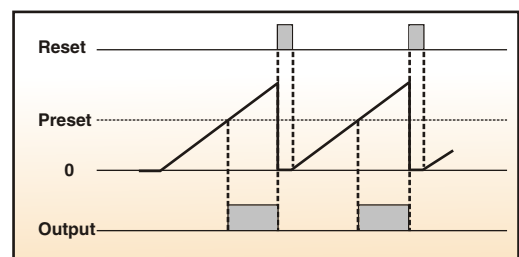

- **ON Delay:** When input power is applied timing (t) begins, during which the output relay remains de-energized. At the end of the preselected time (t), relay energizes. The output relay is de-energized when power is removed, thus resetting the timer for the next cycle.
- **Reset:** Removing input voltage resets the time delay and output relay.

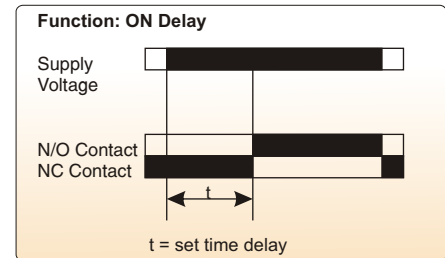

- **Interval Delay:** Applying the power supply starts the time delay & the output relay gets energized. At the end of the preset time, the contact gets de-energised. The timer is reset when the input power is removed.
- **Reset:** Removing input voltage resets the time delay and output relay.

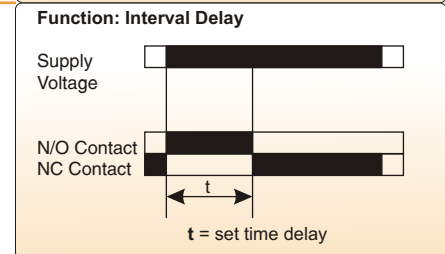

- **Pulse Output:** Applying the power supply starts the time delay, during which the output relay remains de-energized. At the end of the preset period, the relay gets energized for a preset time P(P=500ms). At the end of time P again relay de-energizes.
- **Reset:** Removing input voltage resets the time delay, output relay and the sequence.

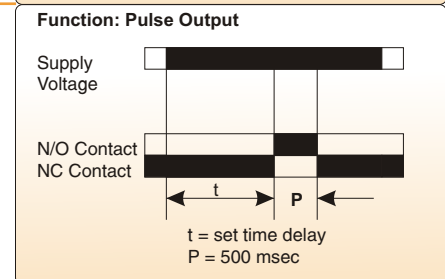

- **Repeat Cycle Equal (OFF First):** Upon application of input voltage, the output relay remains de-energized and time t begins. At the end of the time t, output relay energizes for set time t. At the end of time t again relay de-energizes and this cycle continues until input voltage is removed.
- **Reset:** Removing input voltage resets the time delay, output relay and the sequence.

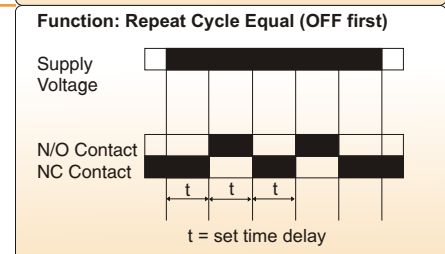

- **Repeat Cycle Equal (ON First):** Upon application of input voltage, the output relay energizes and Time t begins. At the end of the time t, output relay de-energizes for set time t. At the end of time t again relay energizes and this cycle continues until input voltage is removed.
- **Reset:** Removing input voltage resets the time delay, output relay and the sequence.

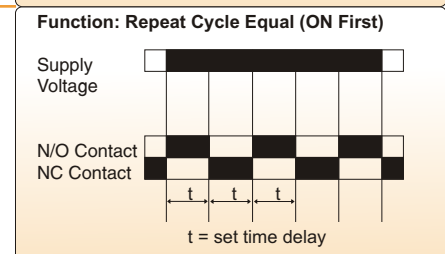

- **Delay on Break:** Input voltage must be applied before and during timing. Upon application of input voltage, the output remains de-energized. On closing the control contact 'Y' the output energizes. The time delay begins when 'Y' is opened. The output remains energized during timing. At the end of the time delay the output de-energizes. The output will energize if 'Y' is closed when input voltage is applied.
- **Reset:** Re-closing the 'Y' contact during timing resets the time delay. Removing input voltage resets the Time delay and output.

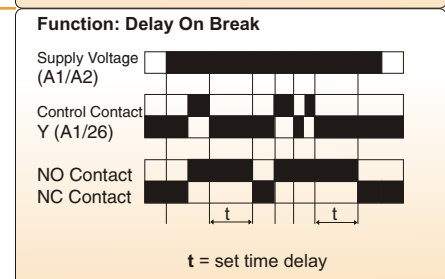

- **Delay on Make with Totalise (Time Storage):** Input voltage must be applied before and during timing. The output is de-energized before and during the time delay. Each time the 'Y' contact is closed, the time delay progresses; when it opens, timing stops. When the amount of time 'Y' is closed equals the full time delay, the output energizes and remains energized until reset.
- **Reset:** Removing input voltage resets the time delay and output.

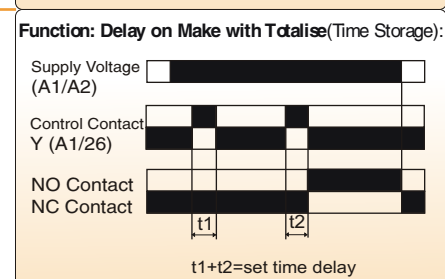

- **Delay on Make / Delay on Break:** Delay on Make time delay t_1 and delay on break time delay t_2 are same i.e. Upon application of input voltage and the closure of 'Y', t_1 begins and the output remains de-energized. At the end of t_1 , the output energizes. Upon the opening of 'Y' t_2 begins. At the end of t_2 , the output de-energizes.
- **Reset:** If 'Y' is opened during t_1 , then t_1 is reset and the output remains de-energized. And if 'Y' is closed during t_2 then t_2 is reset and the output remains energized. Removing input voltage resets the time delay and output

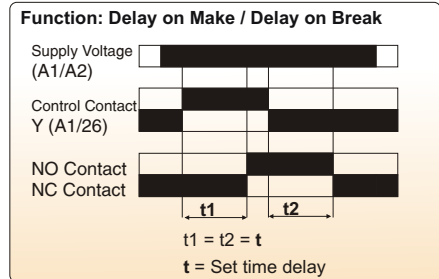

- **Interval after Break:** Input voltage must be applied before and during timing. Upon application of input voltage, the output remains de-energized. On opening (after a closure), the control contact 'Y' the output energizes and time delay begins. The output remains energized during timing. At the end of the time delay the output de-energizes.
- **Reset:** Opening (by closing and then opening) the 'Y' contact during timing resets the time delay. Removing input voltage resets the Time delay and output.

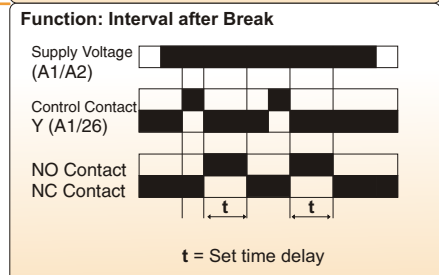

- **Interval with Totalize (Time Storage):** Input voltage must be applied before and during timing. The output is energized before and during the time delay. Each time the 'Y' contact is closed, the time delay progresses; when it opens, timing stops. When the amount of time 'Y' is closed equals the full time delay, the output de-energizes and remains de-energized until reset.
- **Reset:** Removing input voltage resets the time delay and output.

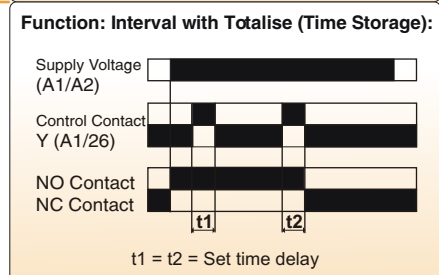

- **Interval on Make / Interval on Break:** Interval on Make time delay t_1 and Interval on break time delay t_2 are same i.e. t . Upon application of input voltage and the closure of 'Y', t_1 begins and the output energizes. At the end of t_1 , the output de-energizes. Upon the opening of 'Y' t_2 begins and the output energizes again. At the end of t_2 , the output de-energizes.
- **Reset:** If 'Y' is opened during t_1 , then t_1 is reset and the output remains energized. And if 'Y' is closed during t_2 then t_2 is reset and the output remains energized. Removing input voltage resets the time delay and output

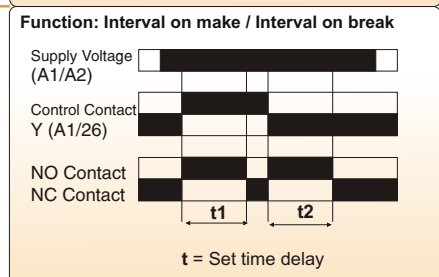

- **Single Shot:** Input voltage must be applied before and during timing. Upon momentary or maintained closure of the control contact 'Y' the output energizes and the time delay begins. At the end of the delay the output de-energizes. Opening or re-closing the 'Y' contact during timing has no effect on the time delay.
- **Reset:** Reset occurs when the time delay is complete and the 'Y' contact is open. Removing input voltage resets the time delay and output.

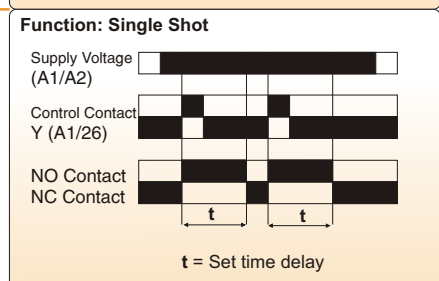

- **Retriggerable Single Shot:** Input voltage must be applied before and during timing. Upon momentary or maintained closure of the control contact 'Y' the output energizes and the time delay begins. At the end of the delay the output de-energizes.
- **Reset:** Re-closing 'Y' contact resets the time delay and restarts timing. Removing input voltage resets the time delay and output.

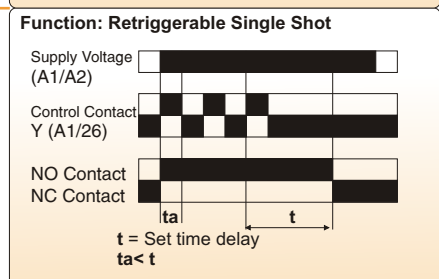

- **Latching Relay:** By closing control contact "Y" of the relay will change it's state and maintain it until power to unit is removed or interrupted.

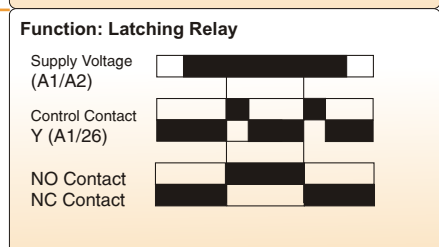

Timing Diagrams for Digital Timers

Applicable for XT543 / XI546 / X1246 / X1346

<p>Function : ON delay</p> <p>Supply Voltage</p> <p>NO Contact</p> <p>$t = \text{Set delay time}$</p>	<p>Function : Cyclic (ON time first)</p> <p>Supply Voltage</p> <p>NO Contact</p> <p>$t_1 = \text{ON time}, t_2 = \text{OFF time}$</p>	<p>Function : ON delay-pulse start</p> <p>Supply voltage</p> <p>Start Contact</p> <p>NO Contact</p> <p>$t = \text{Set delay time}$</p>	<p>Function : Interval delay</p> <p>Supply Voltage</p> <p>NO Contact</p> <p>$t = \text{Set delay time}$</p>
<p>Function : Reset</p> <p>Supply Voltage</p> <p>Reset Contact</p> <p>NO Contact</p> <p>$t = \text{Delay time}$ reset</p>	<p>Function : Cyclic (OFF time first)</p> <p>Supply Voltage</p> <p>NO Contact</p> <p>$t_1 = \text{ON time}, t_2 = \text{OFF time}$</p>	<p>Function: Gate start-ON delay</p> <p>Supply voltage</p> <p>Gate Contact</p> <p>NO Contact</p> <p>$t = \text{delay time} = t_1 + t_2, t_h = \text{hold time}$</p>	

Applicable for XT5042 only

<p>1. ON delay, Interval modes:</p> <p>Supply</p> <p>Start</p> <p>Reset</p> <p>Output ON Delay</p> <p>Output Interval</p>	<p>2. Cyclic ON first, Cyclic OFF first modes:</p> <p>Supply</p> <p>Start</p> <p>Reset</p> <p>Output Cyclic ON</p> <p>Output Cyclic OFF</p>	<p>3. Instantaneous + Delayed at start pulse:</p> <p>Supply</p> <p>Start</p> <p>Reset</p> <p>Instant contact</p> <p>Delayed contact</p>
<p>4. Instantaneous + Delayed at power ON:</p> <p>Supply</p> <p>Reset</p> <p>Instant contact</p> <p>Delayed contact</p>	<p>5. Motor reverse mode:</p> <p>Supply</p> <p>Start</p> <p>Reset</p> <p>Relay 1</p> <p>Relay 2</p> <p>$t_1 = \text{ON time of relay 1}, t_3 = \text{ON time of relay 2}, t_2 = \text{Pause time}$</p>	<p>6. Batch mode</p> <p>Batch reset</p> <p>Preset</p> <p>0</p> <p>Output</p>

Functions in PT380 only

<p>Serial</p> <p>Start Signal</p> <p>ch-1</p> <p>ch-2</p> <p>ch-n</p> <p>Cycle 1</p> <p>ch-1</p> <p>ch-2</p> <p>ch-n</p> <p>Cycle N</p> <p>$n = 8 / 16; N = 0000 \text{ to } 9999 \text{ or continuous}$</p>	<p>Serial (with cascading)</p> <p>Start Signal</p> <p>ch-1</p> <p>ch-n</p> <p>Timer 1</p> <p>ch-1</p> <p>ch-n</p> <p>Timer 2</p>	<p>Parallel</p> <p>Start Signal</p> <p>channel-1</p> <p>channel-2</p> <p>channel-n</p>
--	---	---

642VTR

THREE PHASE MODEL

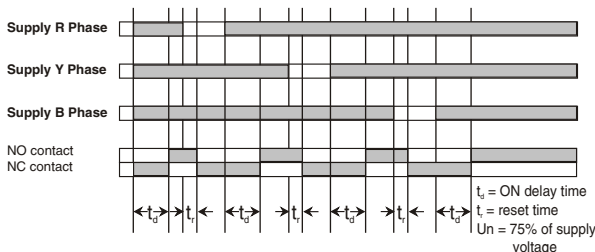

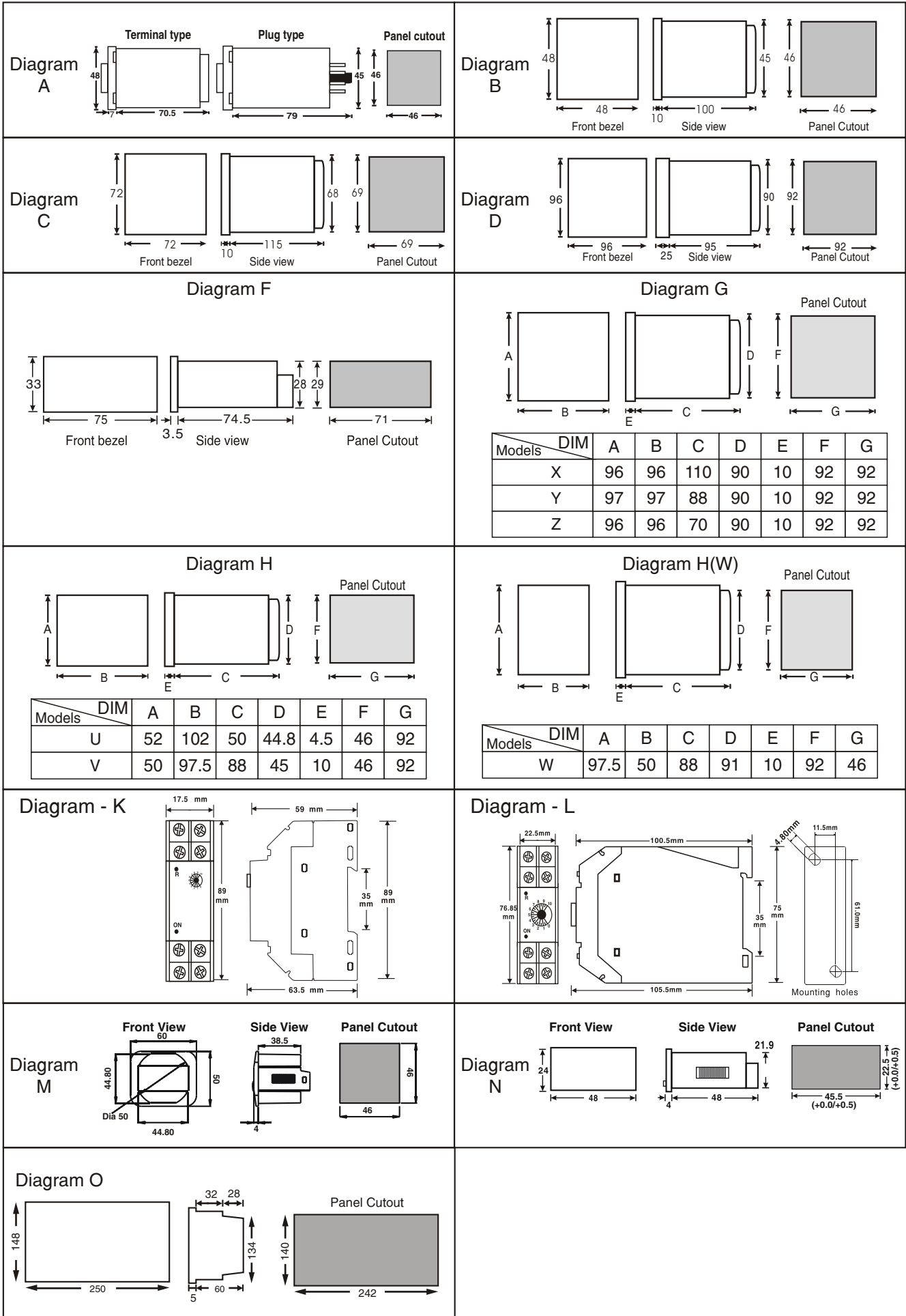

Diagram P(I)

Diagram P(II)

Diagram Q(I)

A	B	C	D	E	F	G
96	96	10	60	90	92	92

Diagram Q(II)

A	B	C	D	E	F	G
99	99	5	46	91	92	92

Diagram Q(III)

A	B	C	D	E	F	G
99	99	5	50	90.5	91.5	91.5

Diagram S

Diagram T

Diagram U

MODELS	DIM	A	B	C	D	E	F	G
TC/XT 5XX		52	52	94	45	4	46	46
TC/XT 2XX		72	72	83.7	67	4.5	69	69
TC/XT 3XX		96	96	73	90.5	5	92	92

Diagram V

Symmetrical 35mm Din Rail (EN50022) Mounting

Diagram W

A	B	C	D	E	F	G
76	76	3.5	50	67.5	67.5	67.5

Table R

	Height	Width	Depth
Zone 1	185.0	95.0	250.0
Zone 2	200.0	145.0	250.0
Zone 4	210.0	300.0	290.0
Zone 6	220.0	385.0	290.0
Zone 8	210.0	590.0	290.0
Zone 12	220.0	690.0	290.0

SELEC[®]

Creating Best Value

Selec Controls Pvt. Ltd.

(An ISO 9001:2008 Company)

Regd. Office

E-121, Ansa Industrial Estate,
Saki Vihar Road, Andheri (E)
Mumbai 400 072
INDIA

Tollfree: 1800 22 7353 (BSNL/MTNL only)

Tel.: +91-22-4039 4200 / 4202

Fax: +91-22-2847 1733

Web: www.selec.com

Email: sales@selec.com

Factory

EL-27/1, Electronic Zone,
TTC Industrial Area, MIDC,
Mahape, Navi Mumbai - 400 710
INDIA

Tel: 91-22-4141 8482

Fax: 91-22-2762 1385

Email: mahape@selec.com